



<b>Table of Contents</b>	
<b>1. INTRODUCTION.....</b>	<b>1</b>
Features.....	1
What it comes with .....	3
<b>2. OPERATION BASICS .....</b>	<b>4</b>
Mounting .....	4
Powering up.....	7
Display and Keypad.....	8
Menus .....	10
Modes.....	11
Tools.....	13
<b>3. ACCIDENT RECONSTRUCTION USE .....</b>	<b>14</b>
Initial Setup .....	14
Get VC4000 Ready .....	15
Measuring Drag Factor.....	19
Testing Brake Performance.....	20
Measuring Coefficient of Friction.....	21
Low Speed Impacts .....	23
Measuring slope .....	26
Avoiding False Triggering.....	28
Acceleration Testing .....	28
Accel/Brake Run.....	31
<b>4. TRANSIT USE .....</b>	<b>33</b>
Initial Setup .....	33
Get VC4000 Ready .....	34
Testing Brake Performance.....	37
<b>5. ENGINEERING USE.....</b>	<b>39</b>
Initial Setup .....	39
Get VC4000 Ready .....	39
Testing Brake Performance.....	42
Acceleration Testing .....	44
Monitor Data .....	48
<b>6. TOOLS.....</b>	<b>49</b>
Monitor Data .....	50
Crash Mode .....	56
Calibration Check .....	57
Delete Run.....	60
Compass Calibration .....	61
SD Card Options .....	63

Accel/Brake Runs .....	65
Setup Summary .....	66
Enter Suffix .....	66
<b>7. VC4000 SETUP .....</b>	<b>67</b>
Setup Flowchart .....	69
G Threshold .....	71
Vehicle ID .....	71
Set Defaults .....	72
Select Named Setup .....	73
Date/Time .....	73
Pitch/Roll Factors .....	74
User Type .....	76
Imperial/Metric .....	78
RS232 Port .....	79
Brake MPH .....	80
Sensors Setup .....	80
Internal Sensors .....	81
Analog Sensors .....	83
OBDII Sensors .....	84
Tach On/Off .....	86
Tach Factors .....	86
Analog Out .....	86
GPS Sensors .....	87
Accelerometer Setup .....	88
G Summation .....	88
G Smoothing .....	90
Zeroing On/Off .....	91
Accelerometer Range .....	91
G Adjust .....	91
Graph Range .....	92
Alarm Threshold .....	92
Sample Rate .....	93
Performance Setup .....	93
Vehicle Weight .....	93
Countdown On/Off .....	94
Tachometer On/Off .....	94
Tach Factors .....	94
Maintenance .....	95
Unit Information .....	95
Run Tests .....	95
Discharge Battery .....	95
<b>8. SENSOR INPUT .....</b>	<b>96</b>
Internal Sensors .....	97
Compass .....	97

Rate Gyro .....	97
Tachometers .....	97
Digital IN 1 and 2 .....	98
Analog Sensor Input .....	100
Sensor Requirements .....	100
Junction Box .....	101
OBDII Input .....	102
Tachometer Input .....	103
Analog Output.....	105
GPS Input .....	106
External Activation .....	107
<b>9. REVIEW - PRINT DATA .....</b>	<b>110</b>
Display a Run .....	110
Store to SD Flash drive .....	111
<b>10. PC INTERFACE.....</b>	<b>112</b>
RS232 Ports .....	113
USB Port.....	114
Bluetooth.....	115
<b>11. UPDATING FIRMWARE.....</b>	<b>117</b>
<b>12. CHARGING THE BATTERY .....</b>	<b>119</b>
<b>13. CUSTOMER SERVICE.....</b>	<b>120</b>
Warranty .....	120
Repairs .....	120
Options, Upgrades and Accessories .....	122
<b>14. TROUBLESHOOTING.....</b>	<b>123</b>
<b>15. SPECIFICATIONS .....</b>	<b>125</b>

# VERICOM VC4000DAQ PERFORMANCE AND BRAKING TEST COMPUTER OWNERS MANUAL

Revision 1.10.0, October 15, 2010

## 1. INTRODUCTION

**D**ecades of refinement make the VC4000 the best yet. The VC4000 has been designed for ease of use and simplicity of operation for quick and easy results, yet has advanced features for doing much more. The unit is **preprogrammed** with standard defaults so that it is ready to operate immediately. The new VC4000DAQ measures X, Y and Z axis acceleration, yaw rate, compass heading, as well as accepting inputs from external sensors and tachometers. The more acquainted you become with the VC4000 the more applications you will discover.

## VC4000DAQ Features

- **3-axis** accelerometer
- Profile **Professional** included
- **Single** vacuum cup mounting
- **Summation** of X+Y+Z vectors
- Selectable **G range** of 2 or 6 G
- Angular **rate gyro** for yaw or pitch measurement
- **GPS** speed and position (with GPS module)
- Up to 115 minutes of data **storage time**
- SD **flash memory** card
- **Bluetooth** wireless communication
- **OBDII** input compatible, CAN or RS232
- 12 analog **sensor input**
- **Analog** output of sensor or tachometer
- 4 **tachometer** inputs
- 2 extra **digital** inputs (event markers)
- **Compass** for heading information
- **Menu** selection software
- 3 x **RS232** ports
- **USB** port
- **Updateable** firmware via USB interface
- **Delete** individual Runs
- **Battery** shows charging on display and LED on front
- Audible **G alarm**
- Calculates **adjusted** braking distance
- Can send data directly to Profile (**Data Streaming**)
- **Variable** sample rate of 1, 10, 100, 500 or 1000Hz

This manual covers everything necessary to operate your VC4000. For further information and details, see our web site [www.vericomcomputers.com](http://www.vericomcomputers.com) and go to the support page. There will be documents with tips on various subjects. Look to the support pages for firmware updates for your VC4000.

### How to use this manual

The gray area on the page edges allow you to quickly thumb through to find the section you want. Use the Table of Contents at the beginning to quickly search for the general section you are interested in. If you can't find what you are looking for, go to our web site's support pages for more detailed information.

## What it comes with

Check to see that the following items are supplied with your VC4000:

- 1 VC4000 with single cup mounting assembly
- 1 Power cord (to cigarette lighter)
- 1 AC wall adapter
- 1 USB interface cable
- 1 6 port analog input junction box
- 1 OBDII CAN interface cable
- 1 VC4000 manual
- 1 Profile CD
- 1 Carrying case

Optional Accessories:

- RS232/Analog out splitter
- RS232 (ports 2-3) splitter
- Tachometer/CAN/digital in splitter
- GPS input
- OBDII input
- Tachometer interfaces
- Activation switches
- Reaction time switches
- Analog sensors (see web site for most current list)
- Portable thermal micro printer
- Variety of mounting bases
- Two cup mounting system
- Extra carrying case

## 2. OPERATION BASICS

This section will give you basic operating procedures for the VC4000DAQ.

### Mounting

The VC4000 does not have to be level to get accurate results. It uses a 3 axis accelerometer and calculates the **vector sum** of all 3 axes to calculate G force, speed and distance. G “Summation 3D (XYZ)” must be on in Setup. It is **on** by default. See page 88 for details. Mount the VC4000 so the display is roughly facing the back of the vehicle, or so the X-axis is roughly along the front to back line of the vehicle.

**Figure 1: Single mount on windshield**





**Figure 4: Dual cups mount**

1. If you do not wish to use the batteries, plug the power cord into the back of the VC4000 and into the vehicle's cigarette lighter.
2. Plug external accessories such as sensors or GPS into VC4000 before turning power on. See page 96 for connection description.

**Figure 5: Assembly w/single vacuum cup**

## Powering up

### Battery

The VC4000 has a **semi-permanent** internal battery pack that will run for at least 6 hours before it needs recharging. The battery pack can be changed by the user if it does not hold a charge anymore. The unit can be operated from the battery or plugged into a vehicle's accessory jack (cigarette lighter) while testing. The battery will charge while plugged into the vehicle. Accessories such as analog sensors and GPS will discharge the battery quicker since they draw power from the VC4000. It can also be powered and recharged from the wall adapter. Recharging will take up to 3 hours. While charging, the charging indicator on the front will light and if the unit is turned on the battery gauge on the display will show arrows.

### Turning on and off

Plug in any accessories before powering on. Hold the power key for about **1 second** to turn the unit on. To turn the power off hold the power key for about 1 second until the unit beeps and displays a message to release the power key.



### Safety Circuit

The VC4000 has safety circuits in place for accidental shorting or reverse polarity of sensors or power input. If a sensor draws too much current it will shut the power off to the unit. Sometimes when a sensor is plugged in when the VC4000 power is on the unit will shut off due to the inrush current when the sensor first powers on. This is why we recommend plugging in all accessories with the power off.

### Static Shock

If the unit is struck with ESD (electrostatic discharge) the display may go blank, or less likely the unit may shut off. Push a key on the keypad to see if the display comes back. You may have to get back to the READY screen to make the display re-appear.

## Display and Keypad

### Display

The VC4000 uses a graphic and text display. It has **large** letters so it is easy to see from a distance, such as on a windshield when viewing from the drivers' seat. The display and keypad are lighted for viewing in low light. The light will go out after a few minutes if a key has not been pressed. It will light again when a key is pressed.

### Keypad







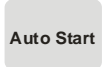
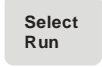

The keypad has 16 keys with the numeric side laid out like an industry standard telephone keypad.

**Figure 6: Keypad and Display**

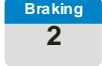
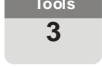
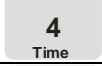
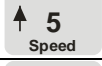

Many keys have more than one function, depending on what the display shows. See the following table.

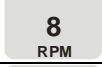
Key function table:

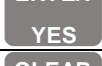
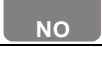
Key	Function
	Press after pressing Braking or Acceleration to sense the G-Force activation threshold.
	Select a run from memory to display or print, and to perform SD flash memory functions.
	While viewing a run, press to toggle between graph and data of run.
	Hold down for 1 second to turn unit on. Hold down for 1 second to turn unit off.
	Start an acceleration test or enter the numeric 1.
	Start a brake test or enter the numeric 2.
	Show the Tools menu or enter the numeric 3.
	Enter the numeric 4 or display a time graph.
	Enter the numeric 5, display a speed graph or scroll up.
	Enter the numeric 6 or display a distance graph.
	Enter the numeric 7, scroll the cursor left, display a G-Force graph or display detailed G-Force data for an acceleration run.
	Enter the numeric 8, display an RPM graph or display detailed RPM data for an acceleration run.
	Enter the numeric 9, scroll the cursor right or scroll through sensor graphs.
	Enter the numeric 0 or scroll down.
	Enter information, select a menu item or respond YES to a prompt.
	Clear memory, clear information, go back to previous screen or respond NO to a prompt.

## Menus

The VC4000 uses Menus when several choices are available. Use the up and down arrows to **scroll** through the list. Hold down the up or down arrow to quickly scroll through a list. The menus use wrap around so when you reach the end of a list the cursor jumps to the other end of the list. Press **ENTER / YES** to select your choice. Press **CLEAR / NO** to go to the previous screen.

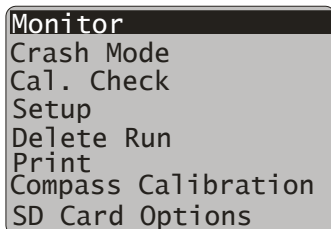

## Modes

The VC4000 has 2 modes: Braking and Acceleration.

### Braking

Use the Braking mode to test a vehicle's brakes or measure the drag

Braking

2

factor of a road surface. From the "READY" screen press **Braking**. Press the **Braking** key while at a **complete stop**. The VC4000 will zero adjust the accelerometers to the current angle the unit is facing. Press the "Auto Start" key before accelerating up to your target speed, or press it after you've reached your target speed if conditions might cause vibration to prematurely activate the unit.

Basic steps for brake testing:

1. Connect sensors if you are using them.
2. Mount the VC4000.
3. Position the vehicle on the same incline as the test is being performed.
4. Press the **Braking** key. Unit will zero adjust itself.
5. Press the **Auto Start** key.
6. Accelerate up to target speed.
7. Apply the brakes hard and fast and come to a complete stop.
8. Use the arrow keys to scroll through the data.

If the **Braking** key was pressed while reviewing data from a previous test, or if the zeroing setting was turned off, it's not necessary to come to a complete stop before pressing the **Braking** key. The VC4000 will use the zero reference from the previous test or if zeroing was turned off it will use the zero reference established at the factory. See page 91 in setup for more details on zeroing.

For further details see application specific sections. Note: Braking mode always uses 100Hz sample rate.

## Acceleration

Use the Acceleration mode to measure time, speed, distance, average G and peak G during acceleration. From the "READY"

Acceleration  
1

screen press **1**. Press the **Acceleration** key while at a complete stop. The VC4000 will **zero adjust** the accelerometers to the current angle the unit is facing. A menu will appear showing some pre-defined tests and a custom choice. Choose **Custom** to make your own test. You may also press the **Auto Start** key to start a **QuickSet™** ¼ mile test.

```
0-30 mph
0-60 mph
0-80 mph
0-100 ft
0-300 ft
0-15 sec
Custom
AutoStart 1/4 mile
```

Basic steps for acceleration testing:

1. Connect sensors if you are using them.
2. Mount the VC4000.
3. Position the vehicle on the same incline as the test is being performed.
4. Press the **Acceleration** key. Unit will zero adjust itself.
5. Select a test from the menu or Press **Auto Start** key for ¼ mile testing.
6. Accelerate up to the end point.
7. Use the arrow keys to scroll through the data.

If the **Acceleration** key was pressed while reviewing data from a previous test, or if the zeroing setting was turned off, it's not necessary to come to a complete stop before pressing the **Acceleration** key. The VC4000 will use the zero reference from the previous test or if zeroing was turned off it will use the zero reference established at the factory. See page 91 in setup for more details on zeroing.

For further details see application specific sections.

# Tools

Tools

3

The VC4000 has several tools available. Press the key to bring up a list of available tools. Below is a list of the tools and a short description of each tool.

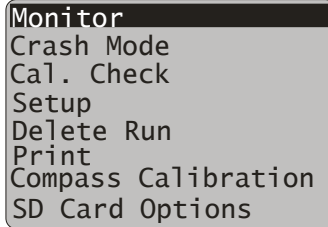

Tool	Description
<b>Monitor</b>	Continuously display built in or external sensors
<b>Crash Mode</b>	Saves data at least 1 second before a high G-Threshold and up to 30 seconds after
<b>Cal. Check</b>	Check calibration on all 3 accelerometers
<b>Setup</b>	Change VC4000 Setup including G-Threshold, G-summation and turn sensors on or off
<b>Delete Run</b>	Delete a run from memory
<b>Print</b>	Print a single or all runs in memory to a portable thermal printer
<b>Compass Calibration</b>	Calibrate the internal compass
<b>SD Card Options</b>	Copy or erase runs from SD Card
<b>Accel/Brake Run</b>	Perform an acceleration test followed by a brake test without stopping to re-zero
<b>Setup Summary</b>	Shows which sensors are turned on in one convenient screen
<b>Enter Suffix</b>	Adds a suffix letter to the run file when saved using Profile 5

## 3. ACCIDENT RECONSTRUCTION USE

This section gives specific instructions on how to use the VC4000 in accident reconstruction.

### Initial Setup

#### User Type

When you first receive your VC4000 the User Type will be set "General" which displays all available data. You should change this setting to "**Accident Reconst.**" User Type. This will show all the data necessary for the accident reconstructionist.

To change the User Type to **Accident Reconstruction**, follow these steps:

1. Press the **Tools** key.
2. Scroll to **Setup** and press **ENTER / YES**.
3. Scroll down to **User Type** and press **ENTER / YES**.
4. Scroll up to **Accident Reconst.** and press **ENTER / YES**.
5. Press **CLEAR / NO** to get back to the READY screen.

Or use Profile to change the setup in the VC4000 from your PC:

1. Start the Profile program
2. Connect the VC4000 to your computer
3. Turn on the VC4000
4. In Profile, Click on the VC4000 Setup icon (or Tools/VC4000 Setup)
5. Profile will get current settings
6. Click the **User Type** drop down box
7. Select **Accident Reconst**
8. Click the "Send Setup" key

ALL settings can be changed using Profile. Not all settings can be changed using the VC4000 keypad.

## Get VC4000 Ready

Do not use this unit in violation of federal, state or local laws. For safety reasons the driver should never press any keys on the VC4000 while the vehicle is in motion. If observation and operation of the VC4000 is required from a moving vehicle, use a separate observer/passenger. Please buckle up and drive safely.

### Mounting

The VC4000 does not have to be level to get accurate results. It uses a 3 axis accelerometer and calculates the **vector sum** of all 3 axes to calculate G force, speed and distance. G “Summation 3D (XYZ)” must be on in Setup. It is **on** by default. See page 88 for details. Mount the VC4000 so the display is roughly facing the back of the vehicle, or so the x-axis is roughly along the front to back line of the vehicle.

**Figure 7: Single mount on windshield**



Alternatively mount the VC4000 flat and level using the single suction cup mount or the dual bracket option with two suction cups.

**Figure 8: Dual cups mount**



### **Mounting Flat and Level**

If mounting flat and level, it is not necessary to use the **Z axis** for calculating the vector sum. In fact, using the Z axis may introduce some error due to vertical vibration caused from the road surface. Either use X or X+Y summation if mounting flat and level. Use the bubble levels on the front and left side of the VC4000 to level it, if your vehicle is reasonably flat and level. Within 3 degrees of level is sufficient to get accurate data. The VC4000 must be **parallel** to the road surface both longitudinally and laterally. If using X only summation, the VC4000 must be positioned parallel to the road surface and the X axis in line with the front to back line of the vehicle.

### **Slope of the road and zero adjusting**

When performing a test the VC4000 will **zero adjust** itself for the slope of the road when you press the **Braking** or **Acceleration** key. If the **Braking** or **Acceleration** key is pressed on the same slope, the Average G-Force (Drag Factor) given by the VC4000 will include the grade of the road. When measuring Drag Factor the road surface does not have to be level; however, you must press the **Braking** key at the same slope you are testing. This will allow the VC4000 to compensate for slope and all data will be accurate. When measuring coefficient of friction ( $\mu$ ) you must zero adjust on a level surface. The vehicle must be at a complete stop during zero adjusting.

Slope A = -0.1  
Slope C = +0.1

Zero adjust at point B  
Do skid test at point A, B or C  
 $f = \mu = 0.800$

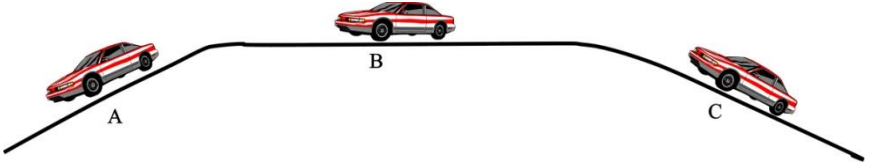

Zero adjust at point A  
Do skid test at point A  
 $f = \mu - \text{slope}$

$$-0.8 (-) + 0.1 = -0.7$$

$$-0.8 + 0.1 = -0.7$$

VC4000 will display -0.700 Ave G

Zero adjust a point C  
Do skid test at point C  
 $f = \mu + \text{slope}$

$$-0.8 (+) - 0.1 = -0.9$$

$$-0.8 - 0.1 = -0.9$$

VC4000 will display -0.900 Ave G

### Attaching accessories

Plug in any accessories before turning the VC4000 power on. It may be easier to plug in cables before mounting the VC4000. If you do not wish to use the batteries on the VC4000 plug the provided power cord into back of VC4000 and into vehicle's accessory jack if one is available. Plug the external activation connector into VC4000 if you are using it (see page 107 for external activation). Plug in other sensors and tachometers if needed.

Figure 9: VC4000DAQ back panel



## Turn on external sensors if using them

Each external sensor or tachometer must be turned on for the VC4000 to record data from it.

1. Press the **Tools** key
2. Scroll to **Setup** and press **ENTER / YES**
3. Scroll down to **Sensors...** and press **ENTER / YES**
4. Choose the sensor you want to record and press **ENTER / YES**
5. See Setup, Sensors on page 80 for details on each sensor
6. Press **CLEAR / NO** twice to get back to the READY screen

Or use **Profile** to change the setup in the VC4000 from your PC:

1. Start the Profile program
2. Connect the VC4000 to your computer
3. Turn on the VC4000
4. In Profile, click on the VC4000 tab, then "VC4000 Setup"
5. Profile will connect and retrieve the VC4000 setup
6. Turn on the sensors using the "sensors" tab
7. Click the "Send Setup" key

## VC4000 Run Storage Memory

The VC4000 stores all braking runs to internal **flash memory**. Eventually the memory will fill up or the number of files will exceed 9,999. When this happens you will have to clear memory. The display will prompt you to clear memory after the error message appears. You should clear run data memory **periodically** to ensure data storage is successful. To clear memory, press the **CLEAR / NO** key from the "READY" screen and follow the prompts. Monitor and acceleration runs can store to internal flash memory or use Data Streaming.

Data Streaming sends the data directly to Profile without storing it in flash memory first. It has a sample rate of 100Hz and can run for up to 24 hours. Use Profile and click on the menu "Import/Data Streaming" to use this feature. See Profile help or Profile manual for more details.

The VC4000DAQ includes an SD flash memory card on which to store run data. To transfer runs onto the SD flash memory card follow these steps:

1. From the "READY" screen, press the **Tools** key.
2. Scroll to **SD Card Options** and press **ENTER / YES**.
3. Select **Copy All Runs** and press **ENTER / YES**.

4. Press **CLEAR / NO** twice to get back to the READY screen.

All runs in the VC4000 memory will be copied onto the SD card. The runs will remain in the VC4000 memory until you delete them. A typical 1GB SD card will hold over 200,000 runs.

## Measuring Drag Factor

The most common use of the VC4000 for an accident reconstructionists is to measure Drag Factor. In the VC4000 **Average Gx is the drag factor** if you pressed the **Braking** key on the same slope as the accident scene.

1. Drive to the area where you want to take a measurement.

2. To power on, press the  key and hold for 1 second until the unit beeps.

3. From the "READY" screen press the  key with the vehicle at a complete stop. The VC4000 will zero adjust the accelerometers and applicable sensors, show the available record time in seconds, display the run number being saved, and then display:

PUSH  
AUTO START

4. Position the vehicle before the scene of the accident allowing enough distance to accelerate to your desired target speed. (As an example back up approximately 300 feet). A typical braking test speed on dry pavement is 30 mph for vehicles equipped with standard brakes and 45 mph for vehicles equipment with ABS.

5. Press the  key. The VC4000 will display 'Auto-Start-Ready' and the current G reading.

6. Accelerate the car to the desired initial braking speed. After reaching the desired initial braking speed, hit the brakes hard and fast, applying maximum brake pedal pressure until the vehicle comes to a complete stop.

- If you wish to do another skid test on the same slope (in the same direction) do not press the **CLEAR / NO** key and the VC4000 will retain the calibration for that grade. Press the "Braking" key and repeat step #4.

## Testing Brake Performance

When testing the performance of a vehicles braking system, perform the tests on a **flat and level** surface. An optional brake pedal activation switch is available if required.

- Drive to an area that is flat and level.



- To power on, press the  key and hold for 1 second until the unit beeps.



- From the "READY" screen press the  key with the vehicle at a complete stop. The VC4000 will zero adjust the accelerometers and applicable sensors, show the available record time in seconds, display the run number being saved, and then display:

PUSH  
AUTO START

- Position the vehicle before the test area allowing enough distance to accelerate to your desired target speed. (As an example back up approximately 300 feet). A typical braking test speed on dry pavement is 30 mph for vehicles equipped with standard brakes and 45 mph for vehicles equipment with ABS.

Auto Start

- Press the  key. The VC4000 will display 'Auto-Start-Ready' and the current G reading.
- Accelerate the car to the desired initial braking speed. After reaching the desired initial braking speed, hit the brakes hard and fast, applying maximum brake pedal pressure until the vehicle comes to a complete stop.

7. If you wish to do another skid test on the same slope (in the same direction) do not press the **CLEAR / NO** key and the VC4000 will retain the calibration for that grade. Press the **Braking** key and repeat step #4.

## Measuring Coefficient of Friction

Drag factor (f) = coefficient of friction ( $\mu$ )  $\pm$  the slope. If you wish to measure  $\mu$  on a slope you must zero adjust on a flat and level surface.

1. Drive to an area that is flat and level.



2. To power on, press the **POWER** key and hold for 1 second until the unit beeps.



3. From the "READY" screen press the **Braking 2** key with the vehicle at a complete stop. The VC4000 will zero adjust the accelerometers and applicable sensors, show the available record time in seconds, display the run number being saved, and then display:

PUSH  
AUTO START

4. Position the vehicle before the test area allowing enough distance to accelerate to your desired target speed. (As an example back up approximately 300 feet). A typical braking test speed on dry pavement is 30 mph for vehicles equipped with standard brakes and 45 mph for vehicles equipment with ABS.

5. Press the **Auto Start** key. The VC4000 will display 'Auto-Start-Ready' and the current G reading.
6. Accelerate the car to the desired initial braking speed. After reaching the desired initial braking speed, hit the brakes hard and fast, applying maximum brake pedal pressure until the vehicle comes to a complete stop.
7. If you wish to do another skid test on the same slope (in the same direction) do not press the **CLEAR / NO** key and the VC4000 will retain the calibration for that grade. Press the **Braking** key and repeat step #4.

**NOTE:** The Average Gx will be the Coefficient of friction ( $\mu$ ), not drag factor because you zero adjusted on a level surface.

#### Information available after a brake test

Use the up **5** and down **0** arrow keys to scroll the data up and down.

- Elapsed Time (E/T):** The time from when the VC4000 was activated (see threshold page 71) until the vehicle came to a complete stop.
- Speed:** Speed of the vehicle when the VC4000 was activated (see threshold page 71).
- Distance:** Distance the vehicle traversed during the braking time.
- Avg. Gx\*:** Average longitudinal G force from when the VC4000 was activated to stop.
- Avg. Gy:** Average lateral G force from when the VC4000 was activated to stop.
- Peak Gx:** The maximum longitudinal G-Force obtained from activation to stop and the time where it occurred.
- Peak Gy:** The maximum positive and negative lateral G-Force obtained from activation to stop.

Reaction Time (R/T): The time from external trigger to the G-Threshold. (Shows only if externally triggered)

R/T Dist: The distance traveled during the reaction time. (Shows only if externally triggered)

G(x.x): The instantaneous G-Force at the corresponding time.

Graphs: Press the **Graph/Data** key to display graphs of the run. Press Speed, Distance, G-Force, or Sensor. Press the same key again to scroll through multiple graphs, such as G-Force or Sensor.

\* The VC4000's Average G force (Drag Factor) is calculated by **summing** the G values and dividing by the number of samples. This will give the same result as using velocity and time.

While reviewing the data after a braking test if the braking key is pressed the VC4000 will start a new braking test using the zero reference established the last time the **Braking** key was pressed from the "READY" screen.

## Low Speed Impacts

Since the VC4000 has a selectable G range of 2 or 6 G's it can be used for low speed impact testing. The range applies to all 3 axis's so all axes are set to either the 2 G range or the 6 G range. The accelerometers accuracy is degraded slightly when in the 6 G range so speed and distance calculations might not be as accurate.

A higher sample rate may also be helpful for low speed impacts. Choose 500Hz or 1000Hz. When using 500Hz sample rate the number of sensors besides the internal accelerometers you can monitor is limited to 13, and 1000Hz is limited to 10 extra sensors.

To use the 6G range for the accelerometers and 1000Hz sample rate:

1. Press the **Tools** key
2. Scroll to **Setup** and press **ENTER / YES**
3. Scroll down to **Accelerometer...** and press **ENTER / YES**
4. Scroll to **Accel Range** and press **ENTER / YES**
5. Choose 6G and press **ENTER / YES**
6. Scroll to **Sample Rate** and press **ENTER / YES**
7. Choose 500 or 1000Hz and press **ENTER / YES**
8. Press **CLEAR / NO** twice to get back to the READY screen

Or use Profile to change the accelerometer range.

Brake Mode, Crash Mode, Acceleration Mode or Monitor may be used for these tests.

### Using Crash Mode

Crash mode automatically changes the VC4000 setup to:

- Pitch/roll factors = 0
- G Range = 6g
- Sample rate = 1000
- G-Threshold = 4xG-Threshold up to 4G

Any sensors that are turned on will still be recorded. Only the above changes are made during the crash mode. When the test is finished Setup is restored to how it was previously.

Up to 10 extra sensors can be turned on and recorded. The VC4000 will record at least one second before impact (4xG-Threshold) and up to 30 seconds after impact. See Tools/Crash Mode on page 56 for more information.

1. Drive to the area where you want to take a measurement, or close, where the slope is the same.



2. To power on, press the **POWER** key and hold for 1 second until the unit beeps.
3. From the "READY" screen press the **Tools** key, then select **Crash Mode** with the vehicle at a complete stop. The VC4000 will zero adjust the accelerometers and applicable sensors, show the available record time in seconds, display the run number being saved, and then display:

AUTO START READY

4. Accelerate the car to the desired initial speed. After reaching that speed, trigger the VC4000 using the external trigger or it will activate when it impacts an object and generates  $\pm 4xG$ -Threshold or more.

## Using Monitor

1. Drive to the area where you want to take a measurement, or close, where the slope is the same.
2. To power on, press the  key and hold for 1 second until the unit beeps.
3. From the "READY" screen press the **Tools** key, then select **Monitor**, then **G-Force**.
4. The display will show:

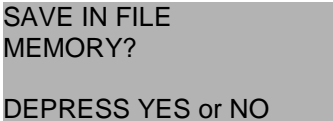



SAVE IN FILE  
MEMORY?  
DEPRESS YES or NO

5. With the vehicle at a complete stop press **ENTER / YES**. The VC4000 will zero adjust the accelerometers and applicable sensors, show the available record time in seconds, display the run number being saved, and then display accelerometer data.
6. Perform your test. Press **CLEAR / NO** to stop saving data.

## Using Brake Mode

**NOTE:** The VC4000 in brake mode will stop recording data when the acceleration is positive again. So during the impact if the accelerometer senses positive acceleration it will end the test. In brake mode the sample rate is always 100Hz.

1. Drive to the area where you want to take a measurement, or close, where the slope is the same.
2. To power on, press the  key and hold for 1 second until the unit beeps.

3. From the "READY" screen press the  key with the vehicle at a complete stop. The VC4000 will zero adjust the accelerometers and applicable sensors, show the available record time in seconds, display the run number being saved, and then display:

PUSH  
AUTO START







4. Press the  key. The VC4000 will display 'Auto-Start-Ready' and the current G reading.
5. Accelerate the car to the desired initial braking speed. After reaching the desired initial braking speed, trigger the VC4000 using the external trigger or tap the brakes hard enough to break the G-Threshold (0.200 default). Then impact the object.

**NOTE:** Be sure to set the G Range back to 2G for other types of testing so speed and distance are more accurate.

## Measuring Slope

The Grade, or Slope, of the road can be very accurately measured using the VC4000. G Summation must be off and Pitch Factor set to 0.

### Set G Summation off and Pitch Factor to 0

1. To power on, press the  key and hold for 1 second until the unit beeps.
2. Press the  key. Scroll to  and press . Scroll down to  and press .

**YES.** Select **G Summation** and press **ENTER / YES**.  
Choose **Summation OFF** and press **ENTER / YES**.

3. Press **CLEAR / NO** to get back to the Setup screen.
4. Scroll up to **Pitch/Roll Factors** and press **ENTER / YES**. Press **↓ 0**, **ENTER / YES**, then **CLEAR / NO**. Press **CLEAR / NO** to get back to the Tools screen.

### Measure the slope

1. Drive to the slope you want to measure, facing directly uphill.



2. Scroll up to **Monitor** and press **ENTER / YES** then select **G-Force**.
3. The display will show:

SAVE IN FILE  
MEMORY?  
  
DEPRESS YES or NO

4. With the vehicle at a complete stop press **CLEAR / NO**. The VC4000 will zero adjust the accelerometers and display 0.000 for the Gx axis.
5. Now turn the vehicle 180 degrees so it is facing downhill and read the Gx value. This number is two times the sine of the angle.



6. Use this formula to calculate the grade in percent if the slope is 6 degrees or less:  $(G_x / 2) * 100$ . If the grade is more than 6 degrees use a calculator to find  $\sin^{-1}$  of  $G_x/2$  ( $\sin^{-1} = \text{ArcSine}$ ):

$$\text{Angle in degrees } (\alpha) = \text{ArcSine } \frac{Gx}{2}$$

- To calculate the grade in percent over 6 degrees, first calculate the angle in degrees ( $\alpha$ ). Then calculate the cosine of that angle. Now divide  $Gx/2$  by that number, which gives you the tangent. Now multiply by 100 to get the % grade.

$$\%Grade = \frac{Gx \div 2}{\text{Cos } \alpha} \times 100$$

## Avoiding False Triggering

If you are testing a motorcycle or large truck that decelerates by more than the default 0.200G threshold when shifting or lifting from the accelerator, to avoid false triggering of your braking run, you may press the **Auto Start** key any time after zero adjusting. For example, you may press **Auto Start** **after** the vehicle has reached the desired braking speed and before applying the brakes. If it's not possible to press a key while moving, increase the G-Threshold to 0.300. See Setup, G-Threshold on page 71. The acceleration mode may be used also. Perform a timed test for 10 seconds or the desired time to complete the test. See Acceleration testing on the next page.

## Acceleration Testing

The VC4000 can be used to measure to a preset Time, Speed or Distance. This is useful for:

- Measuring time and speed from a stop sign to a preset distance at an accident scene in an intersection.
- Measuring time and distance to a preset speed.
- Measuring passing time and distance from a preset speed to a preset speed.

## To perform a preset distance test

1. Drive to the area where you want to take a measurement, where the slope is the consistent.



2. To power on, press the **POWER** key and hold for 1 second until the unit beeps.



3. From the "READY" screen press the **Acceleration 1** key with the vehicle at a complete stop. The VC4000 will zero adjust the accelerometers and applicable sensors, show the available record time in seconds, display the run number being saved, and then display:

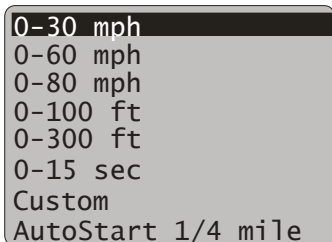

4. Choose one of the presets shown or choose Custom. For Custom, scroll down to **Distance** and press **ENTER / YES**. Type in the distance in feet or meters and press **ENTER / YES**.
5. The VC4000 will display 'Auto-Start-Ready' and the current G reading.
6. Accelerate the vehicle until the VC4000 beeps indicating it has reached the preset distance.
7. For a custom test, if you wish to do another test on the same slope (in the same direction) do not press the **CLEAR / NO** key and the VC4000 will retain the calibration for that grade and use the same custom distance. Press the **Acceleration** key, select **Repeat Last Run** and repeat step #5.

## To perform a preset speed test

1. Drive to the area where you want to take a measurement, where the slope is the consistent.



- To power on, press the **POWER** key and hold for 1 second until the unit beeps.



- From the "READY" screen press the **Acceleration 1** key with the vehicle at a complete stop. The VC4000 will zero adjust the accelerometers and applicable sensors, show the available record time in seconds, display the run number being saved, and then display:

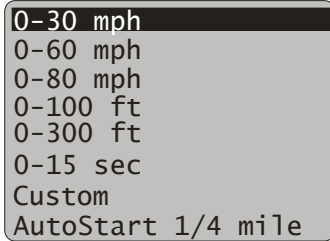

- Choose one of the presets shown or choose Custom. For Custom, scroll down to **Speed** and press **ENTER / YES**.
  - Type in the "START FROM" speed in mph or kph and press **ENTER / YES**. Then type in the "UP TO" speed and press **ENTER / YES**.
- The VC4000 will display 'Auto-Start-Ready' and the current G reading.
- Accelerate the vehicle until the VC4000 beeps indicating it has reached the preset speed.
- For a custom test, if you wish to do another test on the same slope (in the same direction) do not press the **CLEAR / NO** key and the VC4000 will retain the calibration for that grade and use the same custom speeds. Press the **Acceleration** key, select **Repeat Last Run** and repeat step #5.

**Information available after an acceleration test (using User Type Accident Reconst.)**

After an acceleration run, bring the vehicle to a complete stop. The ending Time, Speed, Distance and Average Gx will be displayed.

```

Speed Accel Run
0-60 MPH  5.50 sec
          221 ft

Avg Gx= 0.34

Accel Display (12)▼

```

Press the **Graph/Data** key to display graphs of the run. Press Speed, Distance, G-Force, RPM or Sensor. Press the same key again to scroll through multiple graphs, such as pressing the G-Force key to scroll through longitudinal, lateral or vertical G-Force.

The Acceleration Mode operating limits are:

	<u>Imperial</u>	<u>Metric</u>
Maximum time	99.9 seconds	99.9 seconds
Maximum speed	255 MPH	511 KPH
Maximum distance	9000 feet	1800 meters
Maximum acceleration	+2G	+2G

## Accel/Brake Run

The VC4000 can be used to measure an acceleration test then a brake test from one run. This is useful for measuring the acceleration to a point then getting a drag factor without having to come to a stop and re-zero.

1. Drive to the area where you want to take a measurement, where the slope is the consistent.
2. To power on, press the  key and hold for 1 second until the unit beeps.

- From the "READY" screen press the **Tools** key then select Accel/Brake Run, with the vehicle at a complete stop. It will display:

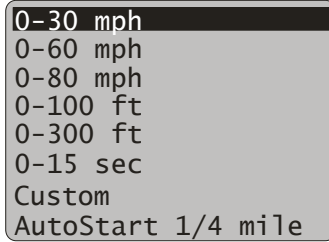

- Choose one of the presets shown or choose Custom. For Custom, scroll down to the measurement needed and press **ENTER / YES**.
  - For Custom, type in the measurement and press **ENTER / YES**.
- The VC4000 will zero adjust the accelerometers and applicable sensors, show the available record time in seconds and display the run number being saved.
- Then it will display 'Auto-Start-Ready' and the current G reading.
- Accelerate the vehicle until the VC4000 beeps indicating it has reached the preset.
- Now apply the brakes to perform a brake test. The unit will beep 5 short times when activated and beep again when at a complete stop.

## 4. TRANSIT USE

This section gives specific instructions on how to use the VC4000 for Transit Bus testing.

### Initial Setup

#### User Type

When you first receive your VC4000 the User Type will be “General” which displays all available data. You should change this setting to “Transit” User Type. This will show all the data necessary for the typical transit vehicle brake test.

To change the User Type to **Transit**, follow these steps:

1. Press the **Tools** key.
2. Scroll to **Setup** and press **ENTER / YES**.
3. Scroll down to **User Type** and press **ENTER / YES**.
4. Scroll up to **Transit** and press **ENTER / YES**.
5. Press **CLEAR / NO** to get back to the READY screen.

Or use Profile to change the setup in the VC4000 from your PC:

1. Start the Profile program
2. Connect the VC4000 to your computer
3. Turn on the VC4000
4. In Profile, Click on the VC4000 Setup icon (or Tools/VC4000 Setup)
5. Profile will connect and retrieve the VC4000 setup
6. Click the **User Type** drop down box
7. Select **Transit**.
8. Click the “Send Setup” key

ALL settings can be changed using Profile. Not all settings can be changed using the VC4000 keypad.

## Get VC4000 Ready

Do not use this unit in violation of federal, state or local laws. For safety reasons the driver should never press any keys on the VC4000 while the vehicle is in motion. If observation and operation of the VC4000 is required from a moving vehicle, use a separate observer/passenger. Please buckle up and drive safely.

### Mounting

The VC4000 does not have to be level to get accurate results. It uses a 3 axis accelerometer and calculates the **vector sum** of all 3 axis to calculate G force, speed and distance. G “Summation 3D (XYZ)” must be on in Setup. It is **on** by default. See page 88 for details. Mount the VC4000 so the display is roughly facing the back of the vehicle, or so the x-axis is roughly along the front to back line of the vehicle.

**Figure 10: Single mount on windshield**



Alternatively mount the VC4000 flat and level using the single suction cup mount or the dual bracket option with two suction cups.

**Figure 11: Dual cups mount**



### **Attaching accessories**

Plug in any accessories before turning the VC4000 power on. It may be easier to plug in cables before mounting the VC4000. If you do not wish to use the batteries on the VC4000 plug provided power cord into back of VC4000 and into vehicle's accessory jack if one is available. Plug external activation connector into VC4000 if you are using it (see page 107 for external activation). Plug in other sensors and tachometers.

**Figure 12: VC4000DAQ back panel**



### **Turn on external sensors if using them**

Each external sensor or tachometer must be turned on for the VC4000 to record data from it.

1. Press the **Tools** key
2. Scroll to **Setup** and press **ENTER / YES**
3. Scroll down to **Sensors...** and press **ENTER / YES**
4. Choose the sensor you want to record and press **ENTER / YES**
5. See Setup, Sensors on page 80 for details on each sensor
6. Press **CLEAR / NO** twice to get back to the READY screen

Or use **Profile** to change the setup in the VC4000 from your PC:

1. Start the Profile program
2. Connect the VC4000 to your computer
3. Turn on the VC4000
4. In Profile, Click on the VC4000 Setup icon (or Tools/VC4000 Setup)
5. Profile will connect and retrieve the VC4000 setup
6. Turn on the sensors using the tabs for each section
7. Click the "Send Setup" key

### VC4000 Run Storage Memory

The VC4000 stores all braking runs to internal **flash memory**. Eventually the memory will fill up or the number of files will exceed 9,999. When this happens you will have to clear memory. The display will prompt you to clear memory after the error message appears. You should clear run data memory **periodically** to ensure data storage is successful. To clear memory, press the **CLEAR / NO** key from the "READY" screen and follow the prompts. Monitor and acceleration runs can store to internal flash memory or use Data Streaming.

Data Streaming sends the data directly to Profile without storing it in flash memory first. It has a sample rate of 100Hz and can run for up to 24 hours. Use Profile and click on the menu "Import/Data Streaming" to use this feature. See Profile help or Profile manual for more details.

The VC4000DAQ includes an SD flash memory card to store run data onto. To transfer runs onto the SD flash memory card follow these steps:

1. From the "READY" screen, press the **Tools** key.
2. Scroll to **SD Card Options** and press **ENTER / YES**.
3. Select **Copy All Runs** and press **ENTER / YES**.
4. Press **CLEAR / NO** twice to get back to the READY screen.

All runs in the VC4000 memory will be copied onto the SD card. The runs will remain in the VC4000 memory until you delete them.

## Testing Brake Performance

When testing the performance of a vehicles braking system, perform the tests on a **flat and level** surface. An optional brake pedal activation switch is available if required.

1. Drive to an area that is flat and level. Connect applicable sensors and activation switch.



2. To power on, press the  key and hold for 1 second until the unit beeps.



3. From the "READY" screen press the  key with the vehicle at a complete stop. The VC4000 will zero adjust the accelerometers and applicable sensors, show the available record time in seconds, display the run number being saved,

PUSH  
AUTO START

and then display:

4. Position the vehicle before the test area allowing enough distance to accelerate to your desired target speed. (As an example back up approximately 300 feet). A typical braking test speed on dry pavement is 20 mph.



5. Press the  key. The VC4000 will display 'Auto-Start-Ready' and the current G reading.
6. Accelerate the car to the desired initial braking speed. After reaching the desired initial braking speed, hit the brakes hard and fast, applying maximum brake pedal pressure until the vehicle comes to a complete stop.

### Information available after a brake test

Use the up **[↑ 5]** and down **[↓ 0]** arrow keys to scroll the data.

**Elapsed Time (E/T):** The time from when the VC4000 was activated (see threshold page 71) until the vehicle came to a complete stop.

**Speed:** Speed of the vehicle when the VC4000 was activated (see threshold page 71).

**Distance:** Distance the vehicle traversed during the braking time.

**Distance (AdjD):** Stopping distance assuming the vehicle was traveling at the target braking speed (usually 20 or 60) when the brakes were applied.

**Avg. Gx:** Average longitudinal G force from when the VC4000 was activated to stop.

**Peak Gx:** The maximum longitudinal G-Force obtained from activation to stop and the time where it occurred.

**1<sup>st</sup> PkGx:** The maximum longitudinal G-Force obtained from activation to 0.75 seconds and the time where it occurred. This is useful to determine if a braking systems mechanical reaction time is sufficient.

**Reaction Time (R/T):** The time from external trigger to the G-Threshold. (Shows only if externally triggered)

**R/T Dist:** The distance traveled during the reaction time. (Shows only if externally triggered)

**Graphs:** Press the **[Graph/Data]** key to display graphs of the run. Press Speed, Distance, G-Force, or Sensor. Press the same key again to scroll through multiple graphs, such as G-Force or Sensor.

While reviewing the data after a braking test if the braking key is pressed the VC4000 will start a new braking test using the zero reference established the last time the **[Braking]** key was pressed from the "READY" screen.

## 5. ENGINEERING USE

This section gives specific instructions on how to use the VC4000 for General and Engineering use.

### Initial Setup

#### User Type

When you first receive your VC4000 the User Type will be set “General” which displays all available data. To limit the displayed data choose one of the other user types. See User Types in Setup for more information.

### Get VC4000 Ready

Do not use this unit in violation of federal, state or local laws. For safety reasons the driver should never press any keys on the VC4000 while the vehicle is in motion. If observation and operation of the VC4000 is required from a moving vehicle, use a separate observer/passenger. Please buckle up and drive safely.

#### Mounting

The VC4000 does not have to be level to get accurate results. It uses a 3 axis accelerometer and calculates the **vector sum** of all 3 axis to calculate G force, speed and distance. G “Summation 3D (XYZ)” must be on in Setup. It is **on** by default. See page 88 for details. Mount the VC4000 so the display is roughly facing the back of the vehicle, or so the x-axis is roughly along the front to back line of the vehicle.

**Figure 13: Single mount on windshield**



Alternatively mount the VC4000 flat and level using the single suction cup mount or the dual bracket option with two suction cups.

**Figure 14: Dual cups mount**



### **Attaching accessories**

Plug in any accessories before turning the VC4000 power on. It may be easier to plug in cables before mounting the VC4000. If you do not wish to use the batteries on the VC4000 plug provided power cord into back of VC4000 and into vehicle's accessory jack if one is available. Plug external activation connector into VC4000 if you are using it (see page 107 for external activation). Plug in other sensors and tachometers.

**Figure 15: VC4000DAQ back panel**



### Turn on external sensors if using them

Each external sensor or tachometer must be turned on for the VC4000 to record data from it.

1. Press the **Tools** key
2. Scroll to **Setup** and press **ENTER / YES**
3. Scroll down to **Sensors...** and press **ENTER / YES**
4. Choose the sensor you want to record and press **ENTER / YES**
5. See Setup, Sensors on page 80 for details on each sensor
6. Press **CLEAR / NO** twice to get back to the READY screen

Or use **Profile** to change the setup in the VC4000 from your PC:

1. Start the Profile program
2. Connect the VC4000 to your computer
3. Turn on the VC4000
4. In Profile, Click on the VC4000 Setup icon (or Tools/VC4000 Setup)
5. Profile will connect and retrieve the VC4000 setup
6. Turn on the sensors using the tabs for each section
7. Click the "Send Setup" key

### VC4000 Run Storage Memory

The VC4000 stores all braking runs to internal **flash memory**. Eventually the memory will fill up or the number of files will exceed 9,999. When this happens you will have to clear memory. The display will prompt you to clear memory after the error message appears. You should clear run data memory **periodically** to ensure data storage is successful. To clear memory, press the **CLEAR / NO** key from the "READY" screen and follow the prompts. Monitor and

acceleration runs can store to internal flash memory or use Data Streaming.

Data Streaming sends the data directly to Profile without storing it in flash memory first. It has a sample rate of 100Hz and can run for up to 24 hours. Use Profile and click on the menu “Import/Data Streaming” to use this feature. See Profile help or Profile manual for more details.



The VC4000DAQ includes an SD flash memory card to store run data onto. To transfer runs onto the SD flash memory card follow these steps:

1. From the “READY” screen, press the **Tools** key.
2. Scroll to **SD Card Options** and press **ENTER / YES**.
3. Select **Copy All Runs** and press **ENTER / YES**.
4. Press **CLEAR / NO** twice to get back to the READY screen.

All runs in the VC4000 memory will be copied onto the SD card. The runs will remain in the VC4000 memory until you delete them.

## Testing Brake

When testing the performance of a vehicles braking system, perform the tests on a **flat and level** surface. An optional brake pedal activation switch is available if required.



1. Drive to an area that is flat and level. Connect applicable sensors and activation switch.
2. To power on, press the  key and hold for 1 second until the unit beeps.
3. From the “READY” screen press the  key with the vehicle at a complete stop. The VC4000 will zero adjust the accelerometers and applicable sensors, show the available record time in seconds, display the run number being saved, and then display:

PUSH  
AUTO START

Auto Start

4. Press the **Auto Start** key. The VC4000 will display 'Auto-Start-Ready' and the current G reading.
5. Accelerate the car to the desired initial braking speed. After reaching the desired initial braking speed, hit the brakes hard and fast, applying maximum brake pedal pressure until the vehicle comes to a complete stop.

### Information available after a brake test

Use the up  5 and down  0 arrow keys to scroll the data.

**Elapsed Time (E/T):** The time from when the VC4000 was activated (see threshold page 71) until the vehicle came to a complete stop.

**Speed:** Speed of the vehicle when the VC4000 was activated (see threshold page 71).

**Distance:** Distance the vehicle traversed during the braking time.

**Distance (AdjD):** Stopping distance assuming the vehicle was traveling at exactly the Brake MPH (usually 20) when the brakes were applied.

**Avg. Gx:** Average longitudinal G force from when the VC4000 was activated to stop.

**Avg. Gy:** Average lateral G force from when the VC4000 was activated to stop.

**Peak Gx:** The maximum longitudinal G-Force obtained from activation to stop and the time where it occurred.

**Peak  $\pm$ Gy:** The maximum positive and negative lateral G-Force obtained from activation to stop.

**1<sup>st</sup> PkGx:** The maximum longitudinal G-Force obtained from activation to 0.75 seconds and the time where it occurred. This is useful to determine if a braking systems mechanical reaction time is sufficient.

**Reaction Time (R/T):** The time from external trigger to the G-Threshold. (Shows only if externally triggered)

R/T Dist: The distance traveled during the reaction time.  
(Shows only if externally triggered)

Graphs: Press the **Graph/Data** key to display graphs of the run. Press Speed, Distance, G-Force, or Sensor. Press the same key again to scroll through multiple graphs, such as G-Force or Sensor.

While reviewing the data after a braking test if the braking key is pressed the VC4000 will start a new braking test using the zero reference established the last time the **Braking** key was pressed from the "READY" screen.

## Acceleration Testing



The VC4000 can be used to measure to a preset Time, Speed or Distance. **QuickSet™** is Vericom's term for one button programming for the ¼ mile. It assumes a ¼ mile acceleration run so programming to 1320 feet is not necessary. The VC4000 records data at 7 other distance points and 2 speeds (called Waypoints) within the ¼ mile (**QuickData™** table).

### To perform a preset distance test

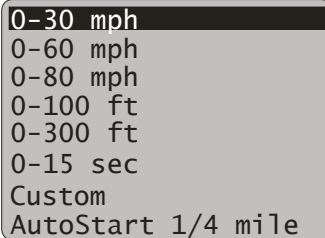
1. Drive to the area where you want to take a measurement, where the slope is the same.
2. To power on, press the  key and hold for 1 second until the unit beeps.





0-30 mph  
0-60 mph  
0-80 mph  
0-100 ft  
0-300 ft  
0-15 sec  
Custom  
AutoStart 1/4 mile

3. From the "READY" screen press the  key with the vehicle at a complete stop. The VC4000 will zero adjust the accelerometers and applicable sensors, show the available record time in seconds, display the run number being saved, and then display:
4. For ¼ mile testing use **QuickSet™** mode by pressing the  key, or scroll down to "AutoStart 1/4 mile" and press **ENTER / YES**.
5. Or choose one of the presets shown or choose Custom. For Custom, scroll down to **Distance** and press **ENTER / YES**. Type in the distance in feet or meters and press **ENTER / YES**.
6. The VC4000 will display 'Auto-Start-Ready' and the current G reading.
7. Accelerate the vehicle until the VC4000 beeps indicating it has reached the preset distance.
8. For a custom test, if you wish to do another test on the same slope (in the same direction) do not press the **CLEAR / NO** key and the VC4000 will retain the calibration for that grade and use the same custom distance. Press the **Acceleration** key, select **Repeat Last Run** and repeat step #6.

The VC4000 will record any "Waypoint" reached using any of the programmed methods.

### To perform a preset speed test

1. Drive to the area where you want to take a measurement, where the slope is the same.
2. To power on, press the  key and hold for 1 second until the unit beeps.
3. From the "READY" screen press the  key with the vehicle at a complete stop. The VC4000 will zero adjust the

accelerometers and applicable sensors, show the available record time in seconds, display the run number being saved, and then display:

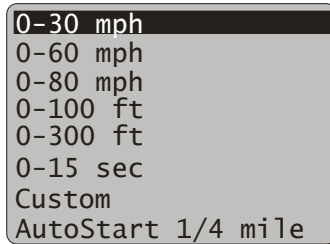

4. Choose one of the presets shown or choose Custom. For Custom, scroll down to **Speed** and press **ENTER / YES**.
  - a. Type in the "START FROM" speed in mph or kph and press **ENTER / YES**. Then type in the "UP TO" speed and press **ENTER / YES**.
5. The VC4000 will display 'Auto-Start-Ready' and the current G reading.
6. Accelerate the vehicle until the VC4000 beeps indicating it has reached the preset speed.
7. For a custom test, if you wish to do another test on the same slope (in the same direction) do not press the **CLEAR / NO** key and the VC4000 will retain the calibration for that grade and use the same custom speeds. Press the **Acceleration** key, select **Repeat Last Run** and repeat step #5.

### Information available after an acceleration test (using User Type General)

After an acceleration run, bring the vehicle to a complete stop. The ending Time, Speed, Distance, instantaneous Gx and Average Gx will be displayed.

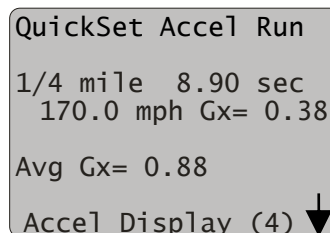

Press the up or down arrow keys to scroll through any data points reached (waypoints) during the test.

Data from the Vericom VC4000 QuickData™				
Distance	Time	Speed	RPM	G-Force
1/4 Mile				
1000 ft				
1/8 Mile				
330 ft				
60 ft				
30 ft				
15 ft				
		60 mph		
		30 mph		
				Peak Gx=
				Peak Gy=
				Peak HP=

Press the **Graph/Data** key to display graphs of the run. Press Speed, Distance, G-Force, RPM or Sensor. Press the same key again to scroll through multiple graphs, such as pressing the G-Force key to scroll through longitudinal, lateral or vertical G-Force.

The Acceleration Mode operating limits are:

	<u>Imperial</u>	<u>Metric</u>
Maximum time	99.9 seconds	99.9 seconds
Maximum speed	255 MPH	511 KPH
Maximum distance	9000 feet	1800 meters
Maximum acceleration	+2G	+2G

## Monitor Data

The VC4000 can **continuously** display and store any internal or external sensor. You may choose to not save the data to conserve memory space if you only require on-screen viewing.

Data to monitor are:

- G-Force – X, Y and Z axis + peaks
- 4 Tachometers + peaks
- 12 Analog sensors
- OBDII Sensors
- GPS speed, location and altitude
- Rate Gyro – yaw rate in Deg./Sec.
- Compass – heading in Degrees
- 2 Digital inputs – On or Off

See section 6 TOOLS/Monitor Data on page 50 for details.

## 6. TOOLS

This section explains the available tools in the VC4000.

Tools

3

The VC4000 has several tools available. Press the key to bring up a list of available tools. Below is a list of the tools and a short description of each.

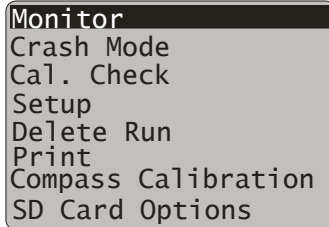
A screenshot of a menu titled "Monitor" with a list of options: Crash Mode, Cal. Check, Setup, Delete Run, Print, Compass Calibration, and SD Card Options.

```
Monitor
Crash Mode
Cal. Check
Setup
Delete Run
Print
Compass Calibration
SD Card Options
```

Tool	Description
<b>Monitor</b>	Continuously display built in or external sensors
<b>Crash Mode</b>	Saves data at least 1 second before a high G-Threshold and up to 30 seconds after
<b>Cal. Check</b>	Check calibration on all 3 accelerometers
<b>Setup</b>	Change VC4000 Setup including G-Threshold, G-summation and turn sensors on or off
<b>Delete Run</b>	Delete a run from memory
<b>Print</b>	Print a single or all runs in memory to a portable thermal printer
<b>Compass Calibration</b>	Calibrate the internal compass
<b>SD Card Options</b>	Copy or erase runs from SD Card
<b>Accel/Brake Run</b>	Perform an acceleration test followed by a brake test without stopping to re-zero
<b>Setup Summary</b>	Shows which sensors are turned on in one convenient screen
<b>Enter Suffix</b>	Adds a suffix letter to the run file when saved using Profile 5

## Monitor Data

The VC4000 can **continuously** display and store any internal or external sensor. You may choose to not save the data to conserve memory space if you only require on-screen viewing. Data may also be transmitted directly to Profile. To use the “Data Streaming” feature in Profile, leave the VC4000 at the “READY” screen and in Profile click on “Import/Data Streaming”.

Data to monitor are:

- G-Force – X, Y and Z axis + peaks
- 4 Tachometers + peaks
- 12 Analog sensors
- OBDII Sensors
- GPS speed, location and altitude
- Rate Gyro – yaw rate in Deg./Sec.
- Compass – heading in Degrees
- 2 Digital inputs – On or Off

Some sensors have to be turned on to monitor. To store the data of the sensors, those sensors have to be turned on in Setup. See “Setup/Sensors...” for details on turning individual sensors on.

### Start Monitor mode:

1. From the “READY” screen press the  key.
2. Select **Monitor**.
3. Choose the sensor to show on the screen.
4. Press **ENTER / YES** to save the data to memory or **CLEAR / NO** to display without saving.

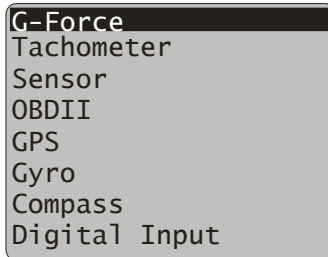

### Storing Data while monitoring

There are two ways to store the data:

1. Start monitor mode on the VC4000 and choose to save in internal flash memory.
2. Start Data Streaming from Profile and store the data to your computer’s hard drive.

If you choose to save the data, the X, Y and Z axis **accelerometers are always stored** when saving to memory regardless of which sensor is being displayed. Any sensors that are turned on will also be stored, regardless of whether it is being displayed or not. If you

are monitoring a sensor that is not turned on it will display the data on the screen but will not save the data to memory.

The Monitor mode limits are about 116 minutes if only the accelerometer data is being stored, or use this formula to calculate the time in seconds if more sensors are turned on:

$$\text{Storage time in seconds} = \frac{2096400}{(\# \text{ of sensors} + 3) \times \text{sample rate}}$$

When using GPS sensors, speed counts as 1 sensor, location counts as 4 sensors, and altitude counts as 1 sensor.

Using **Data Streaming** the maximum run length is 24 hrs, regardless of how many sensors you have turned on. The **USB connection** is recommended since RS232 may be too slow if many sensors are turned on and Bluetooth can be slow and sometimes does not have a reliable connection. To use Data Streaming leave the VC4000 at the READY screen and in Profile click on "Import/Data Streaming". See Profile help or the Profile manual for more detailed information.

### Monitor G-Force

If G Summation is turned off, acceleration in G Force of the X axis (longitudinal), Y axis (lateral) and Z axis (vertical) will display on the screen, along with the peak acceleration of each.

```
Gx = 0.001
Pk+X= 0.002 -X=-0.004
Gy = 0.001
Pk+Y= 0.003 -X=-0.001
Gz = 0.000
Pk+Z= 0.035 -X=-0.021
```

Monitor G Mode

If G Summation is turned on, acceleration in G Force of the vector sum of all three axes will display along with the peaks of the vector sums.

```
G = 0.001
Pk+ = 0.002
Pk- = -0.000
```

Monitor G Mode

When Summation is turned on the VC4000 calculates the vector sum using:

$$G = \sqrt{Gx^2 + Gy^2 + Gz^2}$$

Note that when tilting the VC4000 and using gravity the vector sum will not equal 1.000 G when tilted 90°. This is because the Z axis accelerometer is also zeroed when the X axis accelerometer is zeroed.

### Monitor Tachometer

All four tachometers display at once on the screen. Only the tachometers that are turned on will be saved in memory if saving the data, regardless of what is displayed. The display will show the current RPM of each tachometer as well as the peak RPM of each.

```
RPM1 = 1252 Pk= 11215
RPM2 = 187 Pk= 368
RPM3 = 0 Pk= 0
RPM4 = 0 Pk= 0

Monitor RPM
```

### Monitor Sensor

This is a good way to see if the analog sensors are working correctly.

```
1 Pedal Force 300
  = 0.12 lbs
2 25G Accel
  = 0.004 G
3 String pot 15
  = 0.011 inches
4 100psi pressure
Monitor Sensors
```

Only the sensors that are turned on will display and be saved in memory if saving the data. See page 83 to turn sensors on. Sensors will display scaled values from either the built in named sensors or from the sensor list sent from Profile 5 using VC4000 Setup, "Send Named" button.

### Monitor OBDII

A vehicles OBDII available sensors can be monitored and checked to make sure the VC4000 has a connection to the vehicle. The optional VSI must be used. Any of the 27 available sensors that are

turned on will show here. If saving the data, all OBDII sensors listed will be saved.

```

Protocol Type
SAE J1850
Response Time = 10
OBD Timeouts = 0
Vehicle Speed = 33
Engine RPM = 2045

Monitor OBDII
    
```

### Monitor GPS

With the optional **5Hz GPS antenna**, GPS speed, Latitude, Longitude and Altitude can be monitored, along with the number of satellites in range and other GPS diagnostic information. Plug the GPS sensor into RS232 port one. If saving data and GPS is turned on, GPS speed will be recorded every sample period and Latitude and Longitude will be saved at the beginning and end of the run. If GPS location and altitude are turned on, tracking information will be recorded every 5Hz, which can be tracked on a map within Profile 5.

```

Speed = 0.000
Lat = 45 12.84734 N
Long = 93 32.97201 W
Valid = 2
#Sat = 06
Hdop = 6.800
Alt = 282.600

Monitor GPS
    
```

Display	Meaning
Speed	GPS speed in MPH or KPH if in Metric mode
Lat	Latitude in degrees, minutes.seconds
Long	Longitude in degrees, minutes.seconds
Valid	GPS quality. 0 = no fix, 1 = non-differential, 2 = differential (WAAS), 6 = estimated
#Sat	Number of satellites in use
Hdop	Absolute position accuracy in Meters
Alt	Altitude in Meters

### Monitor Gyro

The Gyro built into the VC4000 is a 150°/sec rate gyro, which means there must be rotation to change the readings. Its maximum rotation

rate is 150° in one second. The gyro must be turned on to monitor it. Use Setup to turn it on. The display will show the rotation rate in Degrees per second, rotation in degrees and peak rotation in degrees. Rotating counterclockwise is negative and clockwise is positive. The calculation to degrees will drift over time due to electronic noise and vibration on the gyro. Press the  key to reset the rotation and peak rotation in degrees to zero. Also exiting the Monitor mode and restarting it will help with the drifting and noise.

```
Gyro = 0.1 Deg/sec  
Rotation = +14.3 Deg  
Peak 18  
  
Monitor Rate Gyro
```

### Monitor Compass

The compass built into the VC4000 is a two-axis magnetometer, which will give the heading of the vehicle from 0 to 360° in 1 degree increments and display the compass reading in N, S, W and E. The compass must be turned on in Setup to monitor it, and must be on with Record to save to memory every sample period.

```
Degrees = 000  
N  
  
Monitor Compass
```

### Monitor Digital Input

The VC4000 can monitor two 5VDC switches using the Digital inputs 1 and 2. Connect the inputs to the “CAN/TACH” port on the VC4000 or the “CAN/TACH/Dig. in.” breakout box. See Setup for details on connection. When monitoring the switches the display will show “ON” or “OFF”. Only the digital inputs that are turned on will be saved in memory if saving the data, regardless of what is displayed.

```
Digital Input 1 = OFF
Digital Input 2 = OFF
```

Monitor Digital

## Crash Mode

Crash mode is similar to Braking mode except some setup items are changed for the test. In this mode the VC4000 saves the data prior to the crash incident, at least one second if all 10 extra sensors are turned on and more time will be captured if less sensors are turned on. A crash incident is defined as acceleration of  $\pm 4$  times the G-Threshold or greater. Default will be  $\pm 0.800$  since the default G-Threshold is 0.200G. The VC4000 will continue to store data until the car has been at a stop for 2 seconds, with a maximum record time of 30 seconds. The 3 accelerometers must not have acceleration values change by more than 0.150G for 2 seconds for the run to end, or it will record to the 30 second max time. You could press any key to stop the recording and it will retain the data stored so far.

### Mounting considerations

Remove the single mounting bracket and mount the VC4000 to a solid plate or object. The optional side pins hardware and base plate may be used for a more solid mount.

Crash mode changes setup during the test to the following:

- Pitch/roll factors = 0
- G Range = 6g
- Sample rate = 1000
- G-Threshold = 4xG-Threshold up to 4G

Extra sensors limit is 10 since the sample rate is changed to 1000. A tri-axis 100G accelerometer, the VC4000 internal yaw rate gyro and the VC4000 compass would be an example of 5 extra sensors. GPS start speed is recorded when the VC4000 is activated at the 4xG-

Threshold and shown in Profile on the “Header...” tab. GPS speed and location every 5Hz can be turned on using Setup.

The VC4000 stores the file as a monitor mode file so when importing to profile it will be an acceleration test, not a braking test.

### Start Crash mode:

1. From the “READY” screen press the **Tools** key, then select **Crash Mode** with the vehicle at a complete stop. The VC4000 will zero adjust the accelerometers and applicable sensors, show the available record time in seconds, display the run number being saved, and then display:

AUTO START READY

2. Accelerate the car to the desired initial speed. After reaching that speed, trigger the VC4000 using the external trigger or it will activate when it impacts an object and generates  $\pm 4xG$ -Threshold or more.

## Cal. Check

The VC4000 accelerometer **calibration** can be checked easily using this tool. No setup changes are necessary when checking calibration this way. Select **Cal. Check** from the list. The VC4000 will prompt you to turn it onto its back, front, each side, top and bottom. The VC4000 does not need to be periodically calibrated. Vericom offers calibration certificates for those that require annual calibration.

This check can be done on a reasonably level desk. All connectors should be unplugged from the back of the unit when performing this check. The Arm for the single suction cup mount should be disconnected from the ball on the VC4000.

ON BACK (-1Gx)  
ON FRONT (+1Gx)  
ON RIGHT SIDE (-1Gy)  
ON LEFT SIDE (+1Gy)  
ON TOP (-1Gz)  
ON BOTTOM (+1Gz)  
Mode - Cal. Check

The first prompt is to set the VC4000 on its back, with the longitudinal accelerometer reading gravity, -1Gx. Turn the unit so its back panel where the connectors are located is facing down flat on the desk and the display is facing up. Hold it there until the unit beeps.

**Figure 16: Calibration check on back**



The second prompt is to turn the VC4000 onto its front, with the longitudinal accelerometer reading gravity in the opposite direction, +1Gx. Turn the unit so its display and keypad are facing down, with the lower half of the unit flat on the desk. Hold it there until the unit beeps.

**Figure 17: Calibration check on front**



The next prompt is to turn the unit on its right side, with the lateral accelerometer reading gravity, -1Gy. The right side is the side

closest to the **CLEAR / NO** key. Set the VC4000 on its right side as straight as possible. Since the sides are not completely flat use a square or other right angle to prop against the bottom to keep the bottom perpendicular to the surface. Hold it there until the unit beeps.

**Figure 18: Calibration check on right side**



Next turn the unit on its left side, +1Gy. Hold it there until the unit beeps.

**Figure 19: Calibration check on left side**



Next turn the unit so its top is flat on the level surface, so the vertical accelerometer is reading gravity, -1Gz. The top is the area with the VERICOM logo. Hold it there until the unit beeps.

**Figure 20: Calibration check on top**



Finally turn the unit so the bottom is flat on the level surface with the vertical accelerometer reading gravity, +1Gz. If the ball mount is attached to the bottom of the unit you will have to hold the unit flat with the ball mount hanging over the edge. Hold it there until the unit beeps.

**Figure 21: Calibration check on bottom**



The VC4000 will show the X, Y and Z axis calibration information. The total range for the X and Y accelerometer should be **1.000 ±0.010** and the Z should be **1.000 ±0.020**.

```
X = 0.999
Y = 1.000
Z = 0.998
```

Mode - Cal. Check

## Delete Run

If you make a mistake and don't want to keep the data or import it to Profile, the run can be deleted. Once deleted it cannot be restored. Select **Delete Run** and choose the file number from the numeric keypad, then press **ENTER / YES** or simply press **ENTER / YES** to select the most recent run without typing in a file number. It will prompt you to press **ENTER / YES** or **CLEAR / NO**. Pressing **ENTER / YES** will delete the run and pressing **CLEAR / NO** will abort the delete process. Deleting the run does not free up any memory.

## Print

If you purchased Vericom's portable **thermal printer**, one run or all the runs stored in memory can be printed on it from the VC4000. The data printed will be the summary information such as Time, Speed, Distance, Average G and Peak G along with a graph of the acceleration vs. time. Connect the printer to one of the RS232 ports using Vericom's thermal printer to VC4000 cable, which can be identified by a sticker that reads "Connect to Printer" on the RJ12 to Dsub converter end. Use Setup to set the RS232 port to "Printer". RS232(1) is set for the printer by default. Select **Print** from the Tools menu, and then choose **Print Run** or **Print All Runs**.

## Compass Calibration

The compass built into the VC4000 must be calibrated **anytime it is moved** to a new vehicle, or even if it is moved to a new mounting location in the same vehicle. This is because the metal in a car has some magnetic fields and blocks or distorts the earth's magnetic field.

**Figure 22: Earth's Magnetic Field**

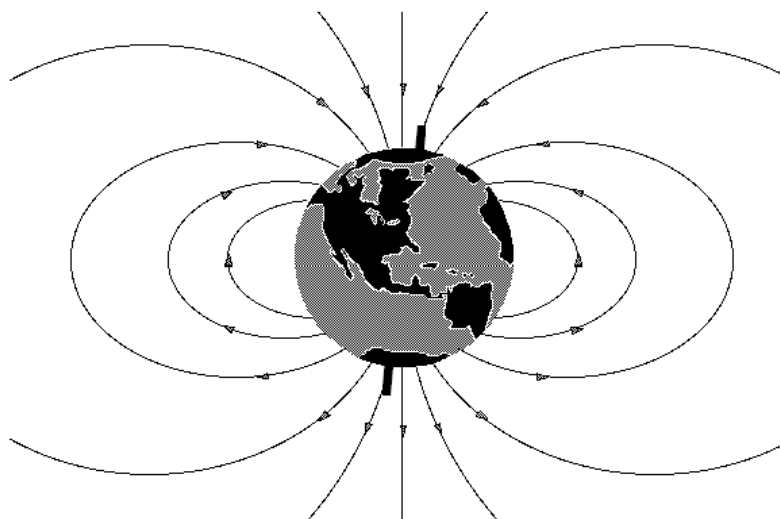

The compass heading shown on the VC4000 is relative to **magnetic heading**, which is not exactly the same as the geographic heading because of how the earth's magnetic fields lay. Also the fields vary by your geographic location on the earth. For instance in central California the difference between magnetic north and geographic north is 16° to the East. So when the VC4000 shows 16° east you are actually pointing geographically north at 0°. See the following declination chart.

**Figure 23: Magnetic declination chart**

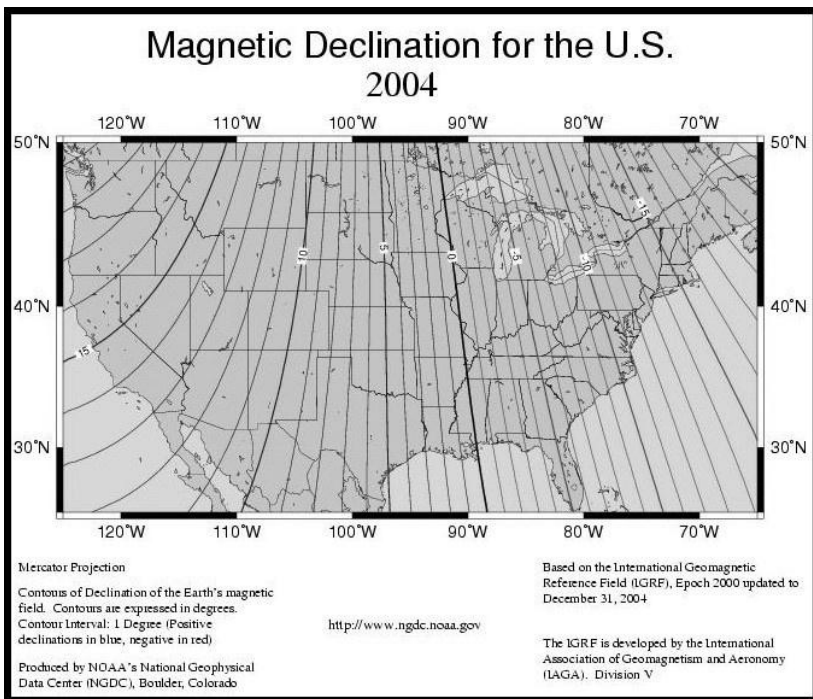

For a more accurate declination chart see web site:  
<http://www.ngdc.noaa.gov/seg/geomag/declination.shtml>  
or search the web for more accurate tools.

**NOTE:** The VC4000 must be mounted **relatively level** to get the most accurate compass data.

## Compass Calibration

1. Install the VC4000 relatively level in the vehicle where it will be mounted during testing.
2. Turn compass on in the VC4000
  - a. Tools/Setup/Sensors.../Sensors Internal/Compass.
  - b. Select **On** or **On-Record** then press **ENTER / YES**.
  - c. Press **CLEAR / NO** 3 times to get back to the Tools menu.
3. Scroll down to Compass Calibration and press **ENTER / YES**.
4. Drive the vehicle in 2 or more complete tight circles.
5. Press **ENTER / YES** to stop the calibration.
6. Display will show some diagnostic information. Press the **ENTER / YES** key to save or **CLEAR / NO** to abort.

## SD Card Options

The VC4000 can copy stored runs onto a **Secure Digital Flash Card** (SD card). The SD card does not need to be installed into the VC4000 during testing. It is used for transferring data from your VC4000 to a computer in lieu of a USB cable, RS232 cable or Bluetooth connection. The VC4000 stores all runs in internal flash memory until you clear them. External flash memory (SD Card) is not fast enough to store the data from the VC4000 as it's running. A typical 1GB SD card will hold over 200,000 runs.

**Figure 24: SD Card slot**



**Figure 25: SD flash memory card**



### **Copy runs to the SD card**

1. Insert SD Card into slot if one is not present.
2. Select **SD Card Options** and press **ENTER / YES**.
3. Select either **Copy All Runs** or **Copy A Run** and press **ENTER / YES**.
4. For one run, type a file number and press **ENTER / YES**.

The SD Card can also be formatted or erased using the VC4000. The SD Card that comes with the VC4000DAQ is pre-formatted. If you use your computer to format the SD Card it must be formatted using FAT filing system, not the FAT32 filing system.

### **Erase and format the SD Card**

1. Select **SD Card Options** and press **ENTER / YES**.
2. Select **Erase SD Card** and press **ENTER / YES**.
3. Press **ENTER / YES** twice to confirm erasure.

The VC4000 stores the data on the SD Card with the file name "RUNxxxxx.VC4" where xxxxx is the run number. Use Profile to open the run files. In Profile, set the file type to "SD Run Files (\*.VC4)".

If copying runs with the same run number to the SD Card the VC4000 will **overwrite** the previous runs. Such as if you copied runs to the SD Card then erased the VC4000 run memory, then made more runs in the VC4000 run memory, then copied the new runs to the SD Card.

Most SD Cards work with the VC4000, but SanDisk has been found to not work with the VC4000.

## Accel/Brake Runs

Perform an acceleration test followed by a brake test without stopping to re-zero. Using the Accel/Brake tool reduces the time it takes to make two tests. The VC4000 will perform the acceleration test first then create a new file number for the subsequent brake test. Internally they will be two separate tests, so Profile will import two separate tests.

For example choose 0 – 60mph for the acceleration test then hit the brakes after reaching 60 mph. The acceleration test would be file 1 and the brake test would be file 2. If you set the brake MPH to 60, you will have data for 0 – 60mph and 60 – 0mph from one test but in two separate files.

1. Drive to the area where you want to take a measurement, where the slope is the consistent.



2. To power on, press the  key and hold for 1 second until the unit beeps.
3. From the “READY” screen press the **Tools** key then select **Accel/Brake Run**, with the vehicle at a complete stop. It will display:

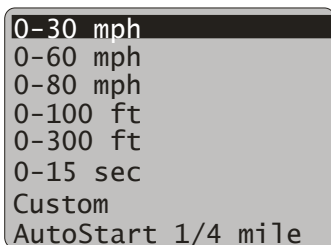

4. Choose one of the presets shown or choose Custom. For Custom, scroll down to the measurement needed and press **ENTER / YES**.
  - a. For Custom, type in the measurement and press **ENTER / YES**.
5. The VC4000 will zero adjust the accelerometers and applicable sensors, show the available record time in seconds and display the run number being saved.

6. Then it will display 'Auto-Start-Ready' and the current G reading.
7. Accelerate the vehicle until the VC4000 beeps indicating it has reached the preset.
8. Now apply the brakes to perform a brake test. The unit will beep 5 short times when activated and beep again when at a complete stop.

## Setup Summary

Displays a summary of what sensors are turned on.

Summary will show:

- Internal Sensors
- Analog Sensors
- GPS Sensors
- OBDII Sensors
- RS232 port connections setup

## Enter Suffix

Adds a suffix letter the run file name when saved using profile. It serves as a way to organize your data during testing. For example you could use the suffix "A" for all the tests at scene A, and "B" for the tests at the next scene, etc.

The run file would then have the format of: *Run0001A\_Brake.run* if it were a brake run and the suffix was set to "A".

# 7. VC4000 SETUP

This section explains the setup options in the VC4000. Each setting is described in detail.

## Setup

The VC4000 has many settings that can be changed to suit your needs. The unit will operate in default mode without any operator intervention. Usually only the sensors need to be turned on or off.

Following is a flowchart to help you navigate to the setting you may want to change. All of these settings can be changed using Profile software as well, and will be easier using Profile since the settings are laid out on forms.

**Figure 26: Profile VC4000 setup window**

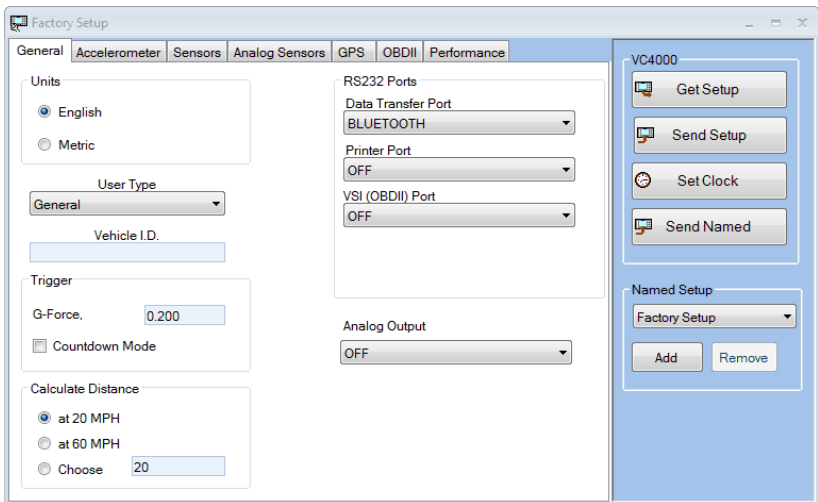

Tools

3

To change setup, click the key and select “Setup”. The VC4000 will store the settings when setup is exited and confirm with a message at the bottom of the screen.

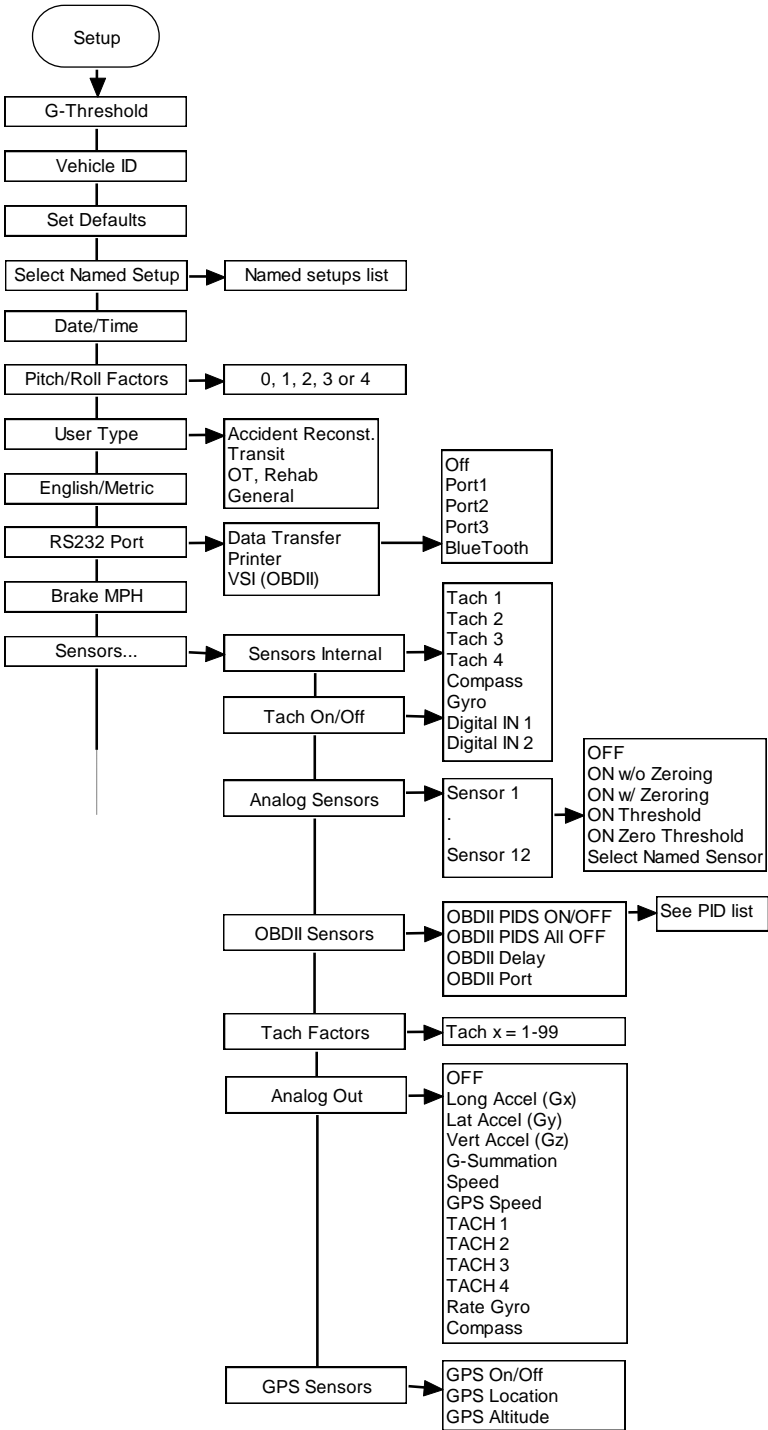

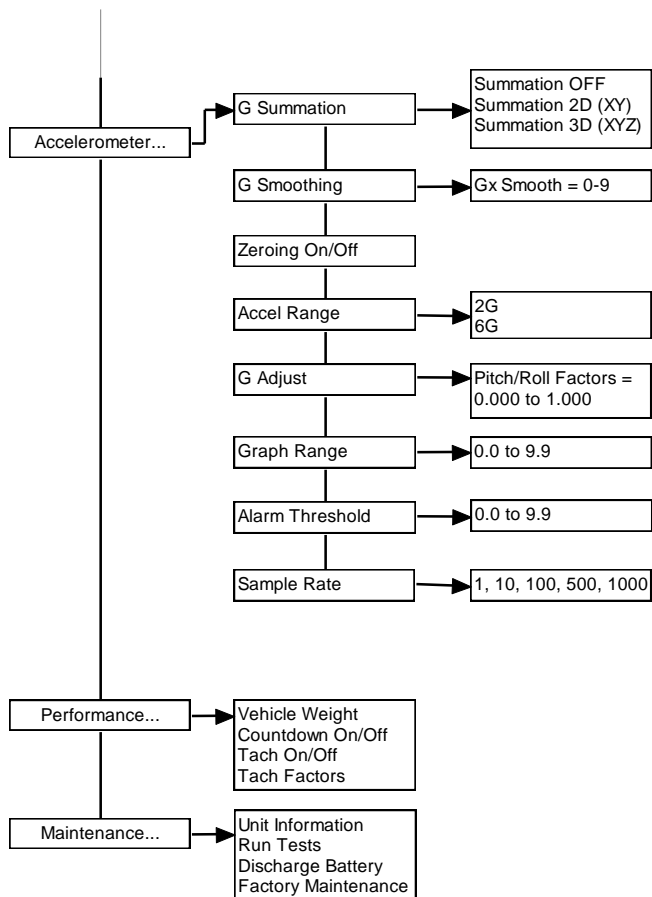

## G-Threshold

When using Auto Start, the VC4000 starts timing your run when the vehicle reaches a  $\pm 0.2G$  threshold. If you launch or brake too gently you will be accelerating or decelerating before the VC4000 considers the run to have started, so your run will be off by that much. Be sure to launch or brake hard enough to trigger the VC4000 the instant the car changes motion; otherwise your data will be off by the time and speed it takes for the car to reach the  $\pm 0.2G$  threshold. If you have trouble launching or braking hard enough to trigger the Auto Start threshold, change the G-Threshold to 0.1G. If the VC4000 is starting too soon such as in a large truck that decelerates quickly when there is no throttle applied, use a 0.3G threshold.

Crash mode will use the G-Threshold and multiply it by 4 for the Crash mode G-Threshold, with a maximum of 4G.

To set G-Threshold:

1. Select **G-Threshold** from the Setup menu
2. Type in the new threshold using the keypad
  - a. For example for 0.100 type 100
3. Press **ENTER / YES**.

G Threshold note: Units shipped with requested New York State specifications have a default threshold of 0.100 G.

## Vehicle ID

The VC4000 allows the user to insert a vehicle ID for each test. The I.D. will print on the thermal printer and will also display in the vehicle field when imported to Profile.

To set Vehicle ID:

1. Select **Vehicle ID** from the Setup menu
2. Type in the new ID using the keypad
3. Press **ENTER / YES**.

## Set Defaults

If your VC4000 is not working properly it may be that some of the settings were **inadvertently changed**. A common problem is when the G-Threshold gets changed to some small number the unit will activate too soon. Try setting defaults to see if that restores it to normal operation. Note that this will change all settings except User Type. The user variables will be set to the values of:

- G-Threshold = 0.200 (See note below)
- Vehicle ID = 0
- Pitch/Roll Factors = 1 (G adjust = 0.9700)
- User Type = Unchanged
- Units = Imperial
- RS232 Port/Printer = Port 1
- RS232 Port/Data Transfer = Bluetooth
- Brake MPH = 20
- Sensors
  - Internal: All OFF
  - Tachometers: All OFF
  - Analog Sensors: All OFF
  - OBDII Sensors: All OFF
  - Tach Factors: All = 8
  - Analog out = OFF
  - GPS Sensors: All OFF
- Accelerometer
  - G Summation = Summation 3D (XYZ)
  - G Smoothing = 3
  - Zeroing ON/OFF = ON
  - Accel Range = 2G
  - G Adjust = 0.9700 (Pitch/Roll = 1)
  - Graph Range = 1.0
  - Alarm Threshold = 0.0
  - Sample Rate = 100
- Performance
  - Vehicle Weight = 1000
  - Countdown = OFF
  - Tachometers: All OFF
  - Tach Factors: All OFF

G Threshold note: Units shipped with requested New York State specifications have a default threshold of 0.100 G.

To set Defaults:

1. Select **Set Defaults** from the Setup menu
2. Press **ENTER / YES**.
3. Press **ENTER / YES** again.

## Select Named Setup

All user configurable settings can be saved to a named setup and recalled before a test on the VC4000. There are 5 predefined setups and 6 user setups. These must be set up in Profile 5 first and sent to the VC4000 using the “**Send Named**” button on the VC4000 Setup dialog. Once the setups are on the VC4000 you can switch between them at any time. See Profile Help for more information on the predefined setups and saving Named setups to disk.

Select the Named setup from the list and all the settings will be configured as you set them in Profile VC4000 Setup. The 5 predefined setups are listed first with the 6 User setups listed next. If there are no custom named setups, they are listed as “Factory Setup”.

Settings recalled include: G-Threshold, accelerometer setup, Sensors with scaling, RS232 port configuration and every setting included on the flowcharts starting on page 69.

## Date/Time

All VC4000's have a date chip that maintains time and date even in the absence of power. It contains a **lithium battery** supply, which will last a minimum of 10 years. The time and date of each run is stored in memory and then uploaded to Profile and stored in the header of Profile for each run. This is useful if the file numbers do not correlate to the test number because you have had to clear memory after making some tests. At least you have the time of day for a reference point.

1. Select **Date/Time** from the Setup menu
2. Set the time for your time zone by entering every number, including zeros. To enter time of 9:00 enter 0, 9, 0, 0.
3. Enter 1 for am or 2 for pm after the digits are entered.
4. Enter the date including zeros. After the date is entered the VC4000 sets the time and date in memory.
5. Alternatively use **Profile** to set the time and date to your computers time and date.

**CLEAR / NO** may be pressed anytime to abort setting the time and date.

## Pitch/Roll Factors

Enter the pitch and roll factors. The default is 1 for each. Pitch is the front-to-back tilt, and roll is the side-to-side tilt. If G summation is either 2D (XY) or 3D (XYZ) the VC4000 will use the Gx pitch factor for the adjustment. Gy (roll) and Gz adjust will have no effect.

**Figure 27: Vehicle axes**  
**Vehicle Axis System**

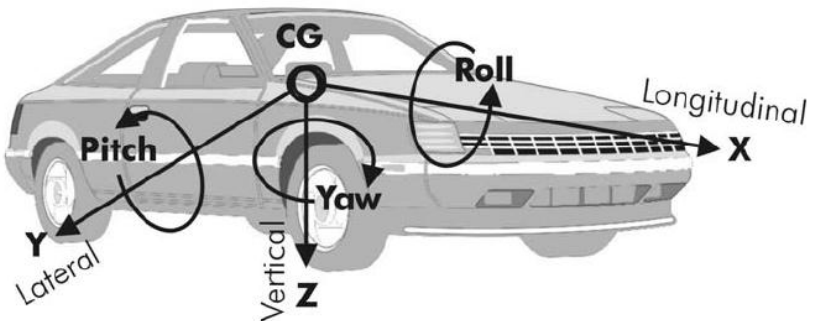

The VC4000 is affected slightly by the tilt of the car caused by suspension shifts under acceleration or deceleration. This effect is slight and for the purposes of the VC4000 is considered to be similar for all vehicles designed to be driven on the highways including motorcycles, passenger cars, semi-tractor trailers and most off road vehicles. The VC4000 is set at a common pitch and roll factor (factor 1) for all vehicles with useful suspension systems.

The VC4000 is shipped with Pitch factor and Roll factor of 1, which is an adjustment of 0.9700. The Pitch and Roll adjustment can be finely adjusted using G adjust.

Using the VC4000's built in rate gyro the pitch and roll can be measured. To measure pitch first turn the rate gyro on, see page 82. Next, mount the VC4000 so the left side of the unit is facing down and the display is facing the back of the vehicle, as usual. Perform a brake test. Import the data to Profile and look at the graph of the rate gyro.

The curve should go down then come back to 0 when the car is fully pitched down. If you add up all the samples from when the curve went down to when it came back up and multiply by the time, you should get the pitch in degrees. For example if you had 0.25 seconds of pitch and they added up to 9.2 deg/sec, then take  $9.2 * 0.25$  to get 2.3 degrees of pitch. Use a calculator to find the sine of 2.3, 0.040, then subtract that from 1.000 to get 0.960 and that is the G-adjustment (Pitch Factor) for that particular vehicle.

Summary:  $9.2\text{deg/sec} * 0.25\text{sec} = 2.3$  degrees.  $\text{Sine } 2.3 = 0.040$ .  $1 - 0.040 = 0.960$  pitch factor.

For rail cars, vehicles with abnormal or no suspension system and marine application the following guide will help you decide which pitch and roll factor to use:

- Pitch and roll factor 0: Low Pitch and roll factor, for vehicles with no suspension system such as transit rail cars, fork lifts or farm tractors. Also for testing on very low friction surfaces such as ice.
- Pitch and roll factor 1: Normal Pitch and roll factor or default Pitch and roll factor, for all highway vehicles with useful suspension systems. Includes motorcycles, passenger cars, semi tractor-trailers and most off road vehicles.
- Pitch and roll factor 2: High Pitch and roll factor, for very short wheel based vehicles with a long suspension travel.
- Pitch and roll factor 3: Very high Pitch and roll factor, for marine or similar application when the bow rises higher than the stern.

Pitch and roll factor 4: Extreme high Pitch and roll factor, for marine or similar application when the bow rises higher than the stern.

To set Pitch and Roll factors:

1. Select **Pitch/Roll Factors** from the Setup menu
2. Type a number from 0 to 4 using the keypad
3. Press **ENTER / YES**.

## User Type

Changing the user type changes the data that is displayed after a test and when runs are selected from memory. In some cases it will change how the test starts and will change other user settings.

### Accident Reconstruction:

Display – Brake mode:

- Reaction Time
- Reaction Time distance
- Elapsed Time
- Speed
- Distance
- Avg. G or avg. Gx if summation not on
- Avg. Gy (only if summation off)
- Peak G or Gx and the time it occurred
- Peak  $\pm$  Gy (only if summation off)
- G every 0.10 sec.

Display – Acceleration mode:

- Time to programmed parameter
- Speed to programmed parameter
- Distance to programmed parameter
- Avg. G or avg. Gx if summation not on

### Transit:

Display – Brake mode:

- Reaction Time
- Reaction Time distance
- Elapsed Time
- Speed
- Distance

- Adjusted Distance to predetermined speed
- Avg. G or avg. Gx if summation not on
- Avg. Gy (only if summation off)
- Peak G or Gx and the time it occurred
- 1<sup>st</sup> Peak Gx and the time it occurred under 0.75 seconds

Display – Acceleration mode:

- Time to programmed parameter
- Speed to programmed parameter
- Distance to programmed parameter
- Avg. G or avg. Gx if summation not on

**OT - Rehab:**

- Does not zero the accelerometer before a run

Display – Brake mode:

- Reaction Time
- Reaction Time distance
- Elapsed Time
- Speed
- Distance

Display – Acceleration mode:

- Time to programmed parameter
- Speed to programmed parameter
- Distance to programmed parameter
- Avg. G or avg. Gx if summation not on

**General:**

Display – Brake mode:

- Reaction Time
- Reaction Time distance
- Elapsed Time
- Speed
- Distance
- Adjusted Distance to predetermined speed
- Avg. G or avg. Gx if summation not on
- Avg. Gy (only if summation off)
- Peak G or Gx and the time it occurred
- Peak  $\pm$  Gy (only if summation off)
- 1<sup>st</sup> Peak Gx and the time it occurred under 0.75 seconds
- G every 0.10 sec

Display – Acceleration mode:

- Time to programmed parameter
- Speed to programmed parameter
- Distance to programmed parameter
- Waypoints
- Avg. G or avg. Gx if summation not on
- Avg. Gy (only if summation off)
- Peak G or Gx at time, speed, dist
- Peak Gy at time, speed, dist (only if summation off)
- Peak HP at time, speed, dist, torque, RPM

#### To set User Type:

1. Select **User Type** from the Setup menu
2. Select user type
3. Press **ENTER / YES**.

## Imperial/Metric

The VC4000 can give Imperial or metric data for braking or acceleration runs.

The Metric data will be displayed in the following units:

KPH:	Kilometers Per Hour
M:	Meters

Metric acceleration runs are limited to 511 KPH and 1800 meters and the start to stop speed must be 10 KPH apart. The QuickSet™ mode will give distance QuickData™ points in Imperial units and speed in metric.

To set Imperial or Metric units:

1. Select **Imperial/Metric** from the Setup menu
2. Select **Imperial or Metric**
3. Press **ENTER / YES**.

## RS232 Port

The VC4000DAQ has 3 RS232, or serial ports. Each can be configured to function as:

- Data Transfer
- Portable thermal printer output (Printer)
- VSI (OBDII) input

Figure 28: RS232 ports



Data transfer can also be set to use **Bluetooth wireless**. See PC Interface/Bluetooth on page 115 for details. To select OBDII using the CAN interface without the VSI converter use Setup/Sensors/OBDII Sensors. GPS is always on RS232 port 1 because that port uses the synchronization signal from the GPS receiver. The VC4000 will automatically recognize the GPS when plugged into RS232 port 1 and turn on GPS speed.

Default is:

- Port 1 GPS
- Port 2 OFF
- Port 3 OFF

To change the RS232 port settings:

1. Select **RS232 Port** from the Setup menu
2. Select the function from the menu
3. Select the port

## Brake MPH

The VC4000 will calculate the distance for an exact speed, as long as the actual test speed and desired target speed are within 5mph. The default is 20 MPH. Speeds from 1 to 100 may be entered.

To set Brake MPH:

1. Select **Brake MPH** from the Setup menu
2. Type in the new speed using the keypad 0-99
3. Press **ENTER / YES**.

## Sensors Setup

The VC4000DAQ has several sensors that can be configured.

Sensor table

<b>Internal sensors (Built into the VC4000 circuitry)</b>	<ul style="list-style-type: none"><li>○ 1 Compass</li><li>○ 1 yaw rate gyro</li><li>○ 4 tachometers (needs external hardware also)</li><li>○ 2 digital inputs (event markers)</li></ul>
<b>12 analog input sensors</b>	<ul style="list-style-type: none"><li>○ 12VDC input to sensors required</li><li>○ 0-5VDC output from sensors required</li></ul>
<b>OBDII sensors</b>	<ul style="list-style-type: none"><li>○ 14 EPA mandated sensors on USA spec vehicles</li><li>○ Connect using CAN cable or VSI interface</li></ul>
<b>1 Analog output port</b>	<ul style="list-style-type: none"><li>○ Output various sensors (see list)</li><li>○ Connect to other data acquisition systems</li></ul>
<b>GPS Sensors</b>	<ul style="list-style-type: none"><li>○ Store position every sample period</li><li>○ Store GPS speed every sample period</li></ul>

# Internal Sensors

Internal sensors consist of:

- 1 Compass
- 1 yaw rate gyro
- 4 tachometer inputs (needs external hardware also)
- 2 digital inputs (event markers)

## Compass

The compass built into the VC4000 is a two-axis magnetometer, which will give the heading of the vehicle, which is the direction the vehicle is pointing, from 0 to 360° in 1 degree increments. Even though it is dual axis it will still only measure in the **horizontal plane**. Two axes are needed to provide accurate compass readings.

In order to get accurate readings from the compass the VC4000 must be mounted **relatively level** so the field strength of the earth's magnetic core is even. The VC4000 must also be mounted inline with the vehicle. The compass must be turned on in Setup to monitor it, and must be on with Record to save to memory every sample period.

The compass must be calibrated in every vehicle it is used in. See "Compass Calibration" in Tools on page 61.

Compass options:

<b>Off</b>	Turns compass off
<b>On</b>	<ul style="list-style-type: none"><li>○ Turns compass on but will not record every sample period.</li><li>○ Will store heading at beginning and end of test when viewed using Profile software</li></ul>
<b>On-Record</b>	<ul style="list-style-type: none"><li>○ Turns compass on</li><li>○ Will record heading every sample period.</li><li>○ Will also store heading at beginning and end of test when viewed using Profile software</li></ul>
<b>Calibration</b>	Calibrate compass for current environment.

To turn the compass on:

1. Select **Sensors...** from the Setup menu
2. Select **Sensors Internal**
3. Select **Compass**
4. Select **On** or **On-Record**

## Gyro

The gyro built into the VC4000 is a 150° per second tuning fork design Rate Gyro. The term “Rate” gyro means it will only measure the rate of rotation, not the rotation itself. Its maximum rotation rate is 150° in one second. In order to get accurate readings from the rate gyro the VC4000 must be mounted **relatively level** in the plane you wish to measure. For example to measure yaw it must be level in the x axis and the y axis. To measure pitch it must be mounted perpendicular to the ground so the y axis is reading 1G.

The gyro must be turned on to monitor and store it.

To turn the Rate Gyro on:

1. Select **Sensors...** from the Setup menu
2. Select **Sensors Internal**
3. Select **Gyro**
4. Select **On**

## Tachometers

There can be up to 4 tachometers connected to the VC4000 at once. The VC4000 monitors and stores any of the 4 channels that are turned on at the selected sample rate. If the signals from the tachometer source are not coming in very fast the RPM will remain at the last known RPM until a new signal is taken. A new RPM reading is calculated for every Tach Factor, so for a Tach Factor of 8 it takes every 8 signals to calculate a new reading.

What can be measured using the tachometers:

- Engine RPM (coil, inductive, magnetic)
- Drive shaft RPM (magnetic)
- Each wheel RPM (wheel speed, magnetic, ABS sensor)

**Tachometer 1** is unique in that it is assumed to be connected to the engine and used for torque and gear ratio calculations in acceleration mode. If it is not connected to the engine, the torque and gear ratio data should be ignored.

One tachometer can be connected to the VC4000 “CAN/Tach 1-4” port directly and will be wired to Tach 1. If more than one tachometer is required the CAN/Tach splitter is must be used. Vericom recommends using our tachometer adapters to make sure the signals are clean and the voltages are correct.

To turn the Tachometers on:

1. Select **Sensors...** from the Setup menu
2. Select **Sensors Internal**
3. Select **Tach x** where x is the tachometer number
4. Select **On**

## Digital IN 1 and 2

The digital inputs on the VC4000 are intended for event markers but can be used for any signal that has 0 and 5VDC output. Commonly the event markers are hand-held switches. The digital sensors must be turned on to store the data from them.

To turn the Digital Inputs on:

1. Select **Sensors...** from the Setup menu
2. Select **Sensors Internal**
3. Select **Digital IN x** where x is 1 or 2
4. Select **On**

## Analog Sensors

Figure 29: Analog sensor inputs

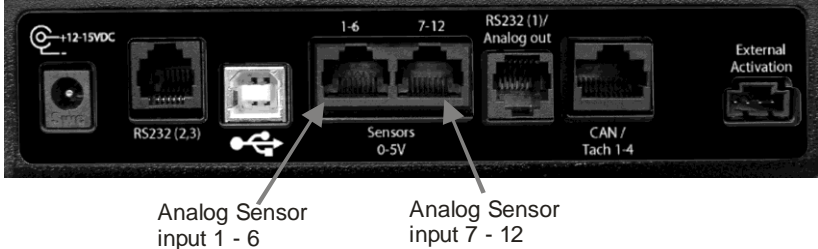

The VC4000 can store data from up to 12 analog sensors. Each one can be turned on individually and setup with or without zero adjusting the sensor. When zero adjusting is selected the VC4000DAQ will set the voltage at the time the internal accelerometers are zero adjusted, as the reference point and anything less will be negative. **Zero adjusting sensors should only be used for accelerometers.** Other sensors that the units range is balanced above and below zero may also use zeroing, so long as the values are supposed to be zero when the VC4000 zero's them. Sensors that range from 0 to a positive number should **not** be zero adjusted.

When a sensor is turned on, that sensor can be used to trigger the start of a run. Select "ON Threshold" or "ON Zero & Threshold" to set the threshold voltage to trigger on. Only one of the external sensors can be used to start a run. The last one selected with the

threshold set will be the selected sensor to trigger from. When a sensor is set to start the run, one of three events may trigger the start of a run: the G-threshold, the external activation or the sensor voltage threshold. If you don't want the G-threshold to start the run, set it high, 1.000 G for example.

To turn the analog sensors on:

1. Select **Sensors...** from the Setup menu
2. Select **Analog Sensors**
3. Select **Sensor x** where x is the sensor number
4. Select **Named Sensor** or **ON** with option (see table)
5. If using a threshold voltage, on the next screen type in a voltage from 0.001 to 5.000.

#### Analog Sensor options

<b>OFF</b>	Turns sensor off, no saving
<b>ON w/o Zeroing</b>	On, don't zero the sensor
<b>ON w/ Zeroing</b>	On, zero the sensor
<b>ON Threshold</b>	On, no zeroing, trigger on a voltage threshold, 0.001 to 5.000V
<b>ON Zero &amp; Threshold</b>	On, zeroing, trigger on a voltage threshold, 0.001 to 5.000V
<b>Select Named Sensor</b>	Select from a preset list. Uses scaling so data is actual values, not voltage

#### Select Named Sensor

This list is downloaded from Profile 5 when the VC4000 Setup, "Send Named" button is used. It is preconfigured in Profile but Vericom may change it in order to add more sensors in the future. If you have a sensor with a unique name and scaling on the "Analog Sensors" tab, that will be used when the "Send Setup" button is used in the VC4000 Setup dialog box.

## OBDII Sensors

The VC4000 can monitor and store up to 14 OBDII parameters. There are more parameters available on OBDII but the others are not normally used so for the sake of simplicity they are not listed.

**NOTE:** The more OBDII sensors you have turned on the slower the vehicles OBDII information will be updated. Turn on as few as possible to get the fastest response from the vehicles computer.

To turn the OBDII sensors on:

1. Select **Sensors...** from the Setup menu
2. Select **OBDII Sensors**

3. Select **OBDII PIDs ON/OFF**
4. Select the parameter to turn on
5. Select **ON**
6. Press **CLEAR / NO** to get back to the OBDII menu
7. Select **OBDII Port**
8. Choose Port 1, 2 or 3 for the VSI connection or CAN for direct connection to a CAN compatible vehicle

### **OBDII PIDs ON/OFF**

Use up and down scroll keys to select the OBDII parameter to be monitored. The following OBDII parameters are available:

- Calculated Load Value
- Engine Coolant Temperature
- Short Trim Fuel Trim – Bank 1
- Long Trim Fuel Trim – Bank 1
- Short Trim Fuel Trim – Bank 2
- Long Trim Fuel Trim – Bank 2
- Fuel Pressure
- Intake Manifold Absolute Pressure
- Engine RPM
- Vehicle Speed
- Ignition Timing Advance
- Intake Air Temperature
- Air Flow Rate
- Throttle Position Sensor

### **OBDII PIDs All OFF**

Sets all OBDII monitoring OFF.

### **OBDII Delay**

Sets the number of milliseconds that the VC4000 will delay before sending the next request for OBDII data. Normally this delay is set to 10 milliseconds but some vehicles require a longer delay to function correctly. If the OBDII timeout count (Monitor OBDII Mode) increments, either a non-supported OBDII parameter is being monitored or this delay needs to be increased.

### **OBDII Port**

Choose Port 1, 2 or 3 for the VSI connection or CAN for direct connection to a CAN compatible vehicle. To connect using CAN you must use Vericom's OBDII CAN to VC4000 cable.

## Tach On/Off

See Sensors Internal/Tachometers.

## Tach Factors

Tach Factor = Number of signals per two engine revolutions. Numbers from 1 to 99 may be entered. Distributor-less ignitions systems will be 2 if connecting to one coil, and an 8-cylinder distributor ignition system will be 8. See the tachometer supplement for various ignition systems settings.

To set the tach factors:

1. Select **Sensors...** from the Setup menu
2. Select **Tach Factors**
3. Type in a tach factor from 1 – 99 for each tachometer, or **CLEAR / NO** to keep the current number
4. Press **ENTER / YES**.

## Analog Out

The VC4000 can connect one of several of its own sensors to another data acquisition system using the Analog out port.

The following sensors are available as analog outputs:

- Longitudinal Accelerometer (Gx)
- Lateral Accelerometer (Gy)
- Vertical Accelerometer (Gz)
- G-Summation (Gxyz)
- Speed (Calculated from VC4000 accelerometers)
- GPS Speed
- Tachometer 1
- Tachometer 2
- Tachometer 3
- Tachometer 4
- Rate Gyro
- Compass

To turn the analog output on:

1. Select **Sensors...** from the Setup menu
2. Select **Analog Out**
3. Select the sensor to use from the list

## GPS Sensor

Vericom has a **5Hz GPS sensor** that connects to RS232 port one on the VC4000. With it GPS location, speed and altitude can be recorded and mapped every 5Hz.

**Figure 30: GPS sensor**



To use it plug the GPS sensor into the RS232 port and the VC4000 will **automatically recognize** it and turn on GPS speed. When GPS speed is on it will store the location at the beginning and end of the run and also store GPS speed every 5Hz.

To turn the GPS location sensor on:

1. Select **Sensors...** from the Setup menu
2. Select **GPS Sensors**
3. Select **GPS Location**
4. Select **ON** to store longitude and latitude every 5Hz for tracking on a map in Profile 5.
5. Turn on **GPS Altitude** to save altitude every 5Hz.

## Accelerometer Setup

The internal accelerometers have several settings.

<b>G Summation</b>	Use X, XY or XYZ axes for acceleration
<b>G smoothing</b>	Smooth acceleration data
<b>Zeroing On/Off</b>	Zero the accelerometers before a test
<b>Accel Range</b>	Choose 2G or 6G maximum acceleration
<b>G adjust</b>	Finely tune the pitch and roll factors
<b>Graph Range</b>	Set the range for the on screen graphs
<b>Alarm Threshold</b>	Set the accelerometer alarm for monitor G mode
<b>Sample Rate</b>	Choose 1, 10, 100, 500 or 1000Hz

### G Summation

<b>Summation OFF</b>	<ul style="list-style-type: none"> <li>○ VC4000 mounted flat and level testing direction in line with the X axis</li> <li>○ Uses X axis only for calculations</li> </ul>
<b>Summation 2D (XY)</b>	<ul style="list-style-type: none"> <li>○ VC4000 mounted flat and level</li> <li>○ Uses the summation of X and Y vectors for G and calculations</li> <li>○ "G" is the summation of X Y vectors</li> <li>○ "Gz" is the vertical axis</li> </ul>
<b>Summation 3D (XYZ)</b>	<ul style="list-style-type: none"> <li>○ VC4000 mounted at any angle</li> <li>○ Uses the summation of X Y and Z vectors for calculations</li> <li>○ "G" is the summation of X Y Z vectors</li> </ul>

Figure 31: VC4000 Axes



Summation of the **acceleration vectors** means taking 2 or 3 acceleration values from different angles and calculating the vector sum. Once the vector sum is calculated it is shown as “G” instead of Gx, Gy and Gz if 3D summation is on.

2D summation:  $G = \sqrt{Gx^2 + Gy^2}$

Figure 32: Vectors

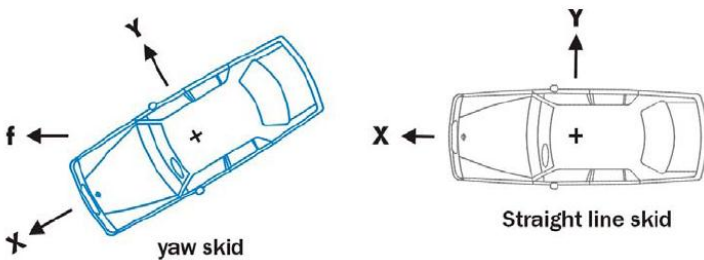

2D summation uses the X and Y axes to calculate a vector sum. This vector sum is then the new acceleration, “G”. The Z axis is still monitored and stored. Use 2D summation if mounting the VC4000 flat and level but the X axis is not necessarily in line with the test direction, such as on an angled windshield like on a split window bus, or on a curved windshield where the VC4000 is mounted to one side. The VC4000 must be mounted with the front to back and side to side level with the road surface when using 2D summation. Use the bubble levels if the surface is level.

3D summation:  $G = \sqrt{G_x^2 + G_y^2 + G_z^2}$

3D summation uses all 3 axes to calculate a vector sum. This vector sum is then the new acceleration, "G". Use 3D summation when mounting the VC4000 at an angle to the road surface, such as with the display tilted up or down.

#### NOTE ON 3D SUMMATION

Since the Z axis accelerometer is included in the calculations when 3D summation is on the VC4000's Z axis accelerometer is sensitive to **road vibration**. This vibration may trigger the VC4000 early if a vertical bump is run over in the road before the test starts. Also, if the surface is bumpy during the test, the accuracy of the acceleration may be degraded.

On rough or bumpy surfaces the best accuracy may be achieved when mounting the VC4000 using 2 suction cups flat and level and using G summation OFF or 2D (XY). On a relatively smooth surface 3D summation accuracy will not be degraded.

To change the G Summation:

1. Select **Accelerometer...** from the Setup menu
2. Select **G Summation**
3. Select OFF, 2D or 3D from the list

Default is 3D (XYZ).

## G Smoothing

Smoothing is used to eliminate some of the **vibration** associated with vehicle testing. Smooth factors from 0 to 9 may be entered for each axis. The G data sent to Profile is the raw data before smoothing and Profile uses the VC4000's smooth factor by default, but can be changed for more or less smoothing effect. See Profile help or the Profile manual to change G smoothing factors in Profile.

If G Summation 2D or 3D is turned on Gx smoothing is used for the summation of the vectors smoothing.

Default is smooth factor of 3 for each axis.

To set the G Smoothing:

1. Select **Accelerometer...** from the Setup menu
2. Select **G Smoothing**
3. Type in a smooth factor from 0 – 9 for each axis, or **CLEAR / NO** to keep the current number
4. Press **ENTER / YES**.

## Zeroing On/Off

The VC4000's accelerometers are set to a zero G reference at the factory on a **calibrated level bench**. When zeroing is turned off the VC4000 will use the zero G reference instead of zeroing before a test. It should be turned off only in isolated cases, such as when zeroing before a test is not possible.

Default is on.

To set the Zeroing On or Off:

1. Select **Accelerometer...** from the Setup menu
2. Select **Zeroing On/Off**
3. Select **Zeroing OFF** or **Zeroing ON**

## Accel Range

The accelerometer in the VC4000 has 2 ranges; 2G and 6G. Use 2G for braking or acceleration testing to use the most resolution possible. Use 6G for light impact testing. Speed and distance calculations may not be as accurate if using the 6G range. The range is for all 3 axes.

To set the Accelerometer Range:

1. Select **Accelerometer...** from the Setup menu
2. Select **Accel Range**
3. Select **2G** or **6G**

Default range is 2G.

## G Adjust

Use this to **finely adjust** the Pitch and Roll factors. The VC4000 is affected slightly by the tilt of the car caused by suspension shifts under acceleration or deceleration. This effect is slight and for the purposes of the VC4000 is considered to be similar for all vehicles designed to be driven on the highways including motorcycles, passenger cars, semi tractor trailers and most off road vehicles. The

VC4000 is set at a common pitch and roll factor (factor 1) for all vehicles with useful suspension systems.

The VC4000 is shipped with “Pitch factor” and “Roll factor” of 1, which is an adjustment of 0.9700 for X and Y axis and a factor of 0 which is an adjustment of 1.000 for the Z axis.

The pitch of the vehicle can be measured using the VC4000’s rate gyro. See Pitch/Roll Factors on page 74 for details.

To set the G Adjust:

1. Select **Accelerometer...** from the Setup menu
2. Select **G Adjust**
3. Type in a number from 0.500 to 1.000 for each axis.
4. Press **ENTER / YES**.

Default adjustment is 0.9700.

## Graph Range

Set the maximum range of the VC4000 acceleration bar graphs and friction circle graph when monitoring acceleration.

To set the Graph Range:

1. Select **Accelerometer...** from the setup menu
2. Select **Graph Range**
3. Type in a number from 0.1 to 6.0.
4. Press **ENTER / YES**.

Default graph range is 1.0.

## Alarm Threshold

There are 3 acceleration alarms that can be set so the VC4000 beeps when the acceleration threshold is exceeded; Accelerating, Braking and cornering. The alarm is turned off when it is set to 0.0.

To set the Alarm Threshold:

1. Select **Accelerometer...** from the Setup menu
2. Select **Alarm Threshold**
3. Type in a number from 0.000 to 6.000.
4. Press **ENTER / YES**.

Default alarm threshold is turned off, 0.0.

## Sample Rate

Sample rate is how often the computer samples all the sensors. 100Hz means it samples 100 times per second, or once every 0.01 seconds. The VC4000 can be set to sample at 1, 10, 100, 500 or 1000Hz for acceleration and monitor mode. Brake mode is always 100Hz regardless of the sample rate setting. If 500Hz is chosen the number of extra sensors that can be turned on is 13. If 1000Hz is chosen the number of extra sensors that can be turned on is 5. Regardless of the sample rate, GPS will only sample every 5Hz and OBDII is limited depending on the vehicle.

To set the Sample Rate:

1. Select **Accelerometer...** from the Setup menu
2. Select **Sample Rate**
3. Select 1, 10, 100, 500 or 1000

Default Rate is 100.

## Performance Setup

These settings generally are for acceleration testing.

## Vehicle Weight

The VC4000 defaults to **1000 pounds** unless you have changed it. Profile reads the VC4000's weight when uploading to a computer. Vehicle weight is used in horsepower and torque calculations only. If you do not change the weight, horsepower and torque will be per 1000 pounds. Simply multiply HP/1000 by vehicle weight (including cargo) to get actual rear wheel HP and torque.

To set the Vehicle Weight:

1. Select **Performance...** from the Setup menu
2. Select **Vehicle Weight**
3. Type in a number from 1 to 99999.
4. Press **ENTER / YES**.

Default weight is 1000.

## Countdown On/Off

Turn countdown on to start the brake or acceleration run with a countdown sequence. When the **Auto Start** key is pressed the VC4000 will delay momentarily, then start the countdown. Acceleration runs use 3333, 2222, 1111 to simulate a drag strip tree with 0.50 sec. between each number and records reaction time. Brake runs use 5555, 4444, 3333, 2222, 1111 with 0.50 sec. between each number. In Acceleration mode the reaction timer starts when 1111 is displayed and the run timer starts when the rollout distance is reached. In Braking mode the run starts when the countdown is completed and the display shows "B R A K I N G".

Default countdown On/Off is Off.

## Tach On/Off

See Sensors.../Sensors Internal/Tachometers on page 82. Tachometers can be turned on here or using Sensors.../Sensors Internal/Tachometers.

## Tach Factors

See Sensors.../Tach Factors on page 86 for a description. Tach Factors can be changed in Performance.../Tach Factors or using Sensors.../Tach Factors.

## Maintenance

Basic maintenance and information.

### Unit Information

Displays the VC4000 model, Firmware version number, the date the firmware was released and when the VC4000 was last calibrated.

### Run Tests

Tests some of the VC4000 hardware. Tests flash memory, accelerometer, real time clock and RS232 ports. **WARNING:** This test will erase all run data stored in memory. If no factory RS232 loopback connector is connected to the RS232 port being tested the VC4000 will report an error on the RS232 port. This is normal.

### Discharge Battery

Allows the battery to discharge quicker by leaving the backlighting on, and discharges more completely by not shutting off when a low battery condition happens.

### Factory Maintenance

Factory only settings.

## 8. SENSOR INPUT

This section explains the hardware associated with each sensor input.

Sensor inputs list

<b>Internal sensors (Built into the VC4000 circuitry)</b>	<ul style="list-style-type: none"> <li>○ 1 Compass</li> <li>○ 1 yaw rate gyro</li> <li>○ 4 tachometers (needs external hardware also)</li> <li>○ 2 digital inputs (event markers)</li> </ul>
<b>12 analog input sensors</b>	<ul style="list-style-type: none"> <li>○ 12VDC input to sensors required</li> <li>○ 0-5VDC output from sensors required</li> </ul>
<b>OBDII sensors</b>	<ul style="list-style-type: none"> <li>○ 14 EPA mandated sensors on USA spec vehicles</li> <li>○ Connect using CAN cable or VSI interface</li> </ul>
<b>1 Analog output port</b>	<ul style="list-style-type: none"> <li>○ Output various sensors (see list)</li> <li>○ Connect to other data acquisition systems</li> </ul>
<b>GPS Sensors</b>	<ul style="list-style-type: none"> <li>○ Store location every sample period</li> <li>○ Store GPS speed every sample period</li> </ul>
<b>External Activation</b>	<ul style="list-style-type: none"> <li>○ Only activates the start of the test</li> <li>○ 5 – 36VDC</li> </ul>

To calculate the total storage time when extra sensors are used, use the formula: 
$$\frac{2096400}{(\# \text{ of sensors} + 3) \times \text{sample rate}}$$

**Example:** 100Hz sample rate, 3 extra sensors turned on:

$$\frac{2096400}{(3 + 3) \times 100} = \frac{2096400}{600} = 3494 \text{ seconds}$$

When using GPS sensors, speed counts as 1 sensor, location counts as 4 sensors, and altitude counts as 1 sensor.

## Internal Sensors

Internal sensors consist of:

- 1 Compass
- 1 yaw rate gyro
- 4 tachometer inputs (needs external hardware also)
- 2 digital inputs (event markers)

### Compass

The compass built into the VC4000 is a two-axis magnetometer, which will give the heading of the vehicle, which is the direction the vehicle is pointing, from 0 to 360° in 1 degree increments. Even though it is dual axis it will still only measure in the **horizontal plane**. Two axes are needed to provide accurate compass readings.

In order to get accurate readings from the compass the VC4000 must be mounted **within 10 degrees** so the field strength of the earth's magnetic core is even. The compass must be turned on in Setup to monitor it, and must be on with Record to save to memory every sample period.

The compass must be calibrated in every vehicle it is used in. See "Compass Calibration" in Tools on page 61.

### Gyro

The gyro built into the VC4000 is a 150° per second tuning fork design Rate Gyro. The term "Rate" gyro means it will only measure the rate of rotation, not the rotation itself. Its maximum rotation rate is 150° in one second. In order to get accurate readings from the rate gyro the VC4000 must be mounted **within 10 degrees** in the plane you wish to measure. For example to measure yaw it must be level in the X axis and the Y axis. To measure pitch it must be mounted perpendicular to the ground so the y axis is reading 1G.

The gyro must be turned on to monitor and store it.

### Tachometers

There can be up to 4 tachometers connected to the VC4000 at once. The VC4000 monitors and stores any of the 4 channels that are turned on at the selected sample rate. If the signals from the

tachometer source are not coming in very fast the RPM will remain at the last known RPM until a new signal is taken. A new RPM reading is calculated for every Tach Factor, so for a Tach Factor of 8 it takes every 8 signals to calculate a new reading.

What can be measured using the tachometers:

- Engine RPM (coil, inductive, magnetic)
- Drive shaft RPM (magnetic)
- Each wheel RPM (wheel speed, magnetic, ABS sensor)

If OBDII is connected and engine speed is turned on, up to 5 tachometers can be monitored at once!

**Tachometer 1** is unique in that it is assumed to be connected to the engine and used for torque and gear ratio calculations in acceleration mode. If it is not connected to the engine, the torque and gear ratio data should be ignored.

One tachometer can be connected to the VC4000 "CAN/Tach 1-4" port directly and will be wired to Tach 1. If more than one tachometer is required the CAN/Tach splitter must be used. Vericom recommends using our tachometer adapters to make sure the signals are clean and the voltages are correct. See tachometer supplements that come with the tachometer decoder boxes for connection and Tach Factor details.

## Digital IN 1 and 2

The digital inputs on the VC4000 are intended for **event markers** but can be used for any signal that has 0 and 5VDC output. Commonly the event markers are hand-held switches. The digital inputs must be turned on to store the data from them.

The digital inputs are accessed using the "CAN/TACH 1-4" port, pins 8 and 9. Pin 8 is digital IN 1 and pin 9 is digital IN 2. Pin 10 on the connector is ground. To wire your own switch, connect pin 8 or 9 to one side of the switch and pin 10 to the other side. The signal will be normally high and low when the key is pressed. A splitter must be used to enable both digital inputs, regardless of connecting directly to the VC4000 or to the CAN/Tach splitter. A 10 pin RJ50 connector is required.

**Figure 33: RJ50 10 pin connector**



**Figure 34: CAN/Tach/Dig. In splitter**

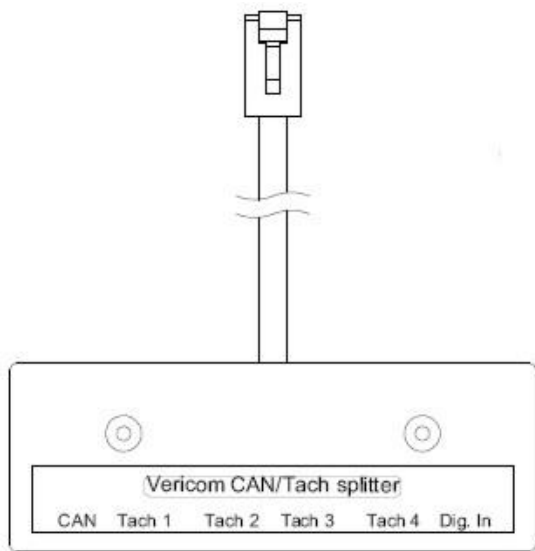

**Figure 35: CAN/Tach/Dig. In wiring**

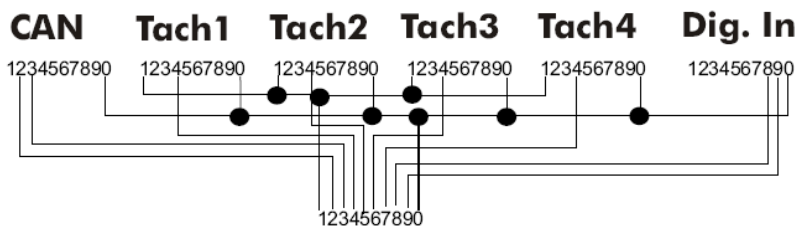

Plug the digital input cable directly into the VC4000 “CAN/Tach 1-4” connector or if using the CAN bus or tachometers plug the cable into the CAN/Tach splitter.

## Analog Sensor Input

The VC4000 can store data from up to **12 analog sensors**. Brake pedal pressure, fluid pressure and string potentiometers are some examples of sensors that can be monitored along with the VC4000 information. The VC4000 has twelve 16-bit A to D converters built in. See Setup/Sensors.../Analog Sensors on page 83 to turn sensors on.

Analog to Digital converter specifications

<b>Input Range</b>	0 – 5VDC
<b>Resolution</b>	16 bits
<b>Accuracy</b>	±0.6 LSB
<b>Supply power</b>	Up to 1.0 Amp

When only one sensor is used, connect it directly to one of the RJ45 connectors on the back of the VC4000 marked “Sensors 0-5V”. Sensors plugged into the jack marked “7-12” will be sensors 7 – 12. When 3 to 12 sensors are needed you will have to use the junction box. See page 101 for junction box.

Profile 5 is used to send the sensor name and scaling to the VC4000. When **VC4000 Setup**, “Send Setup” is used it will set the sensor name and scaling from Profile 5 into the VC4000. Similarly, a predefined named sensor can be chosen from the list in the VC4000. This way the VC4000 will use the scaling information from Profile 5 to show the data in the correct units rather than voltage, and will store the scaling so when importing runs to Profile 5 the sensor scaling will already be set.

### Sensor Requirements

Sensors must have an **RJ45** (Ethernet) connector with pin 1 as 12VDC power input to sensor, pin 2 as the signal out to VC4000 and pin 8 as ground.

**Figure 36: RJ45 connector**

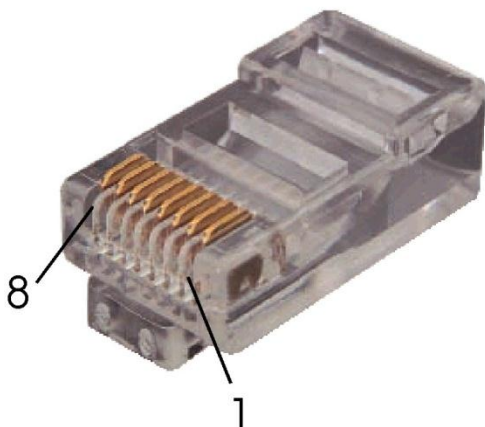

Sensors must have an output in the **range** of 0 – 5 volts DC. The sensor does not necessarily have to have an output of exactly 0 to 5V, but it has to be within that range. For instance a sensor from 1V to 4V will work. The VC4000 can supply up to 1.0 Amps to sensors. Plug in sensors before turning the VC4000 power on.

### **Junction box:**

The junction box is necessary to connect **more than two** sensors to the VC4000DAQ. The output cable from the junction box connects to one of the RJ45 connectors on the back of the VC4000 marked "Sensors 0-5V". The sensors plug into the junction boxes' RJ45 connectors marked 1 through 6. For more than 7 sensors a second junction box must be used.

**Figure 37: Junction box**



## OBDII Input

The VC4000DAQ OBDII Vehicle Sensor Interface option operates on USA-spec OBDII equipped cars. Non USA-spec vehicles may have some data through the OBDII port but not necessarily all the data. All USA-spec vehicles after 1996 are OBDII compliant. The vehicle will have an OBDII connector under the dash or in another location near the driver's seat.

Figure 38: OBDII connector

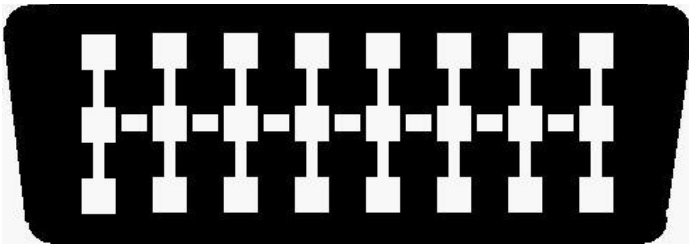

After locating the OBDII connector and with vehicle **running** connect the Vericom OBDII Vehicle Sensor Interface (VSI) to the vehicles OBDII connector.

Figure 39: VSI connector



The Vericom OBDII Vehicle Sensor Interface connects to one of the VC4000's **RS232 ports** on back panel marked "RS232(1)/Analog out" or "RS232 (2,3)". The port must be configured for the VSI and the OBDII sensors must be turned on to store or view them. See Setup/Sensors.../OBDII Sensors on page 84.



If using Vericom's OBDII CAN cable connect the 10 pin RJ50 modular connector end to the VC4000 back panel jack marked "CAN/Tach 1-4" and the other end to the OBDII connector of the vehicle. Set the OBDII input to "CAN".

## Tachometer Input

There can be up to 4 tachometers connected to the VC4000 at once. The VC4000 monitors and stores any of the 4 channels that are turned on at the selected sample rate. See **Setup/Sensors.../Internal Sensors/Tachometers** on page 82 to turn them on.

Figure 40: Tachometer port

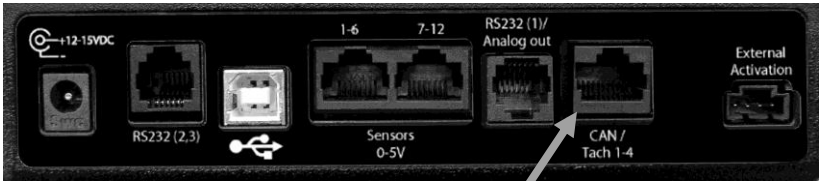

Tachometer port

**Tachometer 1** is unique in that it is assumed to be connected to the engine and will be used for torque and gear ratio calculations in acceleration mode. If it is not connected to the engine, the torque and gear ratio data should be ignored, unless the OBDII engine speed is turned on. When tachometers 2 – 4 are connected, the VC4000 will export the RPM information of each to Profile.

One tachometer can be connected to the VC4000 "CAN/Tach 1-4" port directly and will be wired to Tach 1. If more than one tachometer is required the CAN/Tach splitter must be used. Vericom recommends using our tachometer adapters to make sure the

signals are clean and the voltages are correct. Contact factory for tachometer options.

**Figure 41: Tachometer**

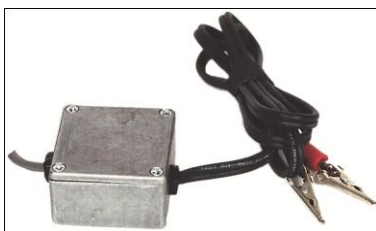

See tachometer supplements that come with the tachometer decoder boxes for connection and Tach Factor details.

**Figure 42: CAN/Tach Dig. In splitter**

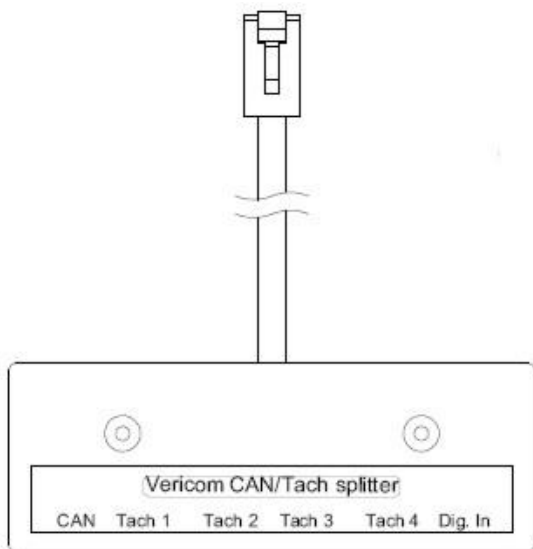

Vericom Tachometer sensors available:

Sensor	Description
Coil tachometer	Connect to negative side of a coil
Inductive tachometer	Clamp around spark plug wire
Magnetic tachometer	Point at magnets of rotating object

Tachometers can measure:

Measure	Sensor needed
Engine RPM	coil, inductive, magnetic
Drive shaft RPM	magnetic
Each wheel RPM	magnetic, ABS sensor

## Analog Output

The VC4000 can connect one of several of its own sensors to another data acquisition system using the Analog out port.

The following sensors are available as analog outputs:

- Longitudinal Accelerometer (Gx)
- Lateral Accelerometer (Gy)
- Vertical Accelerometer (Gz)
- G-Summation (Gxyz)
- Tachometer 1
- Tachometer 2
- Tachometer 3
- Tachometer 4
- Rate Gyro
- Compass
- Speed (Calculated from VC4000 accelerometers)
- GPS Speed

Connect the RJ12 plug of the Analog output cable to the “RS232(1)/Analog out” port of the VC4000, or if using the RS232 and analog out at the same time, to the RS232(1)/Analog out splitter jack marked “Analog out”. The other end is bare wire for connection to another data acquisition system.

Figure 43: RS232/Analog splitter

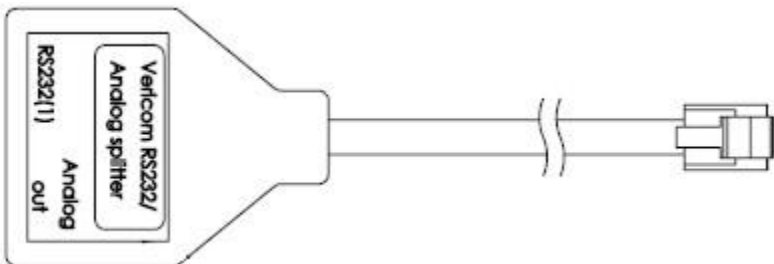

Wiring:

White	Analog out
Black	Ground

See **Setup/Sensors.../Analog out** on page 86 to choose a sensor.

## GPS Input

Vericom has a **5Hz GPS sensor** that connects to RS232 port one on the VC4000. The VC4000 will store GPS location and speed every sample period but the GPS data is only updated every 5Hz (0.20 seconds).

**Figure 44: GPS Sensor**



Plug the RJ12 end into **RS232 port one** on the VC4000 before turning the power on. The VC4000 will **automatically recognize** it and turn on GPS. Route the cable out the passenger side door or window (so it doesn't interfere with driving) and set the magnetic base of the GPS sensor on the roof to get the best reception. When GPS is on it will store the location at the beginning and end of the run and also store GPS speed every 5Hz.

To turn the GPS location sensor on:

1. Select **Sensors...** from the Setup menu
2. Select **GPS Sensors**
3. Select **GPS Location**
4. Select **ON** to store longitude and latitude every 5Hz for tracking on a map in Profile 5.
5. Turn on **GPS Altitude** to save altitude every 5Hz.

## External Activation

Figure 45: Brake pedal activation switch



The External Activation Input is used for starting the run when one of the Reaction timers is used, when 12V is applied, or other input switch is used. This switch allows the operator to **bypass** the Auto Start G-Threshold. When using the external activation switch the activation of the test will be **either** the switch or the G-Threshold (0.2G default) whichever comes first. This switch may be used in the Acceleration mode as well as the Braking mode.

When using the reaction timer switch the run will start the instant a key is pressed and a lamp turns on.

When using the brake light switch or brake pedal switch the brake run will start the instant the brake lights come on or the pedal is touched, which is typically before the 0.2G threshold is reached. Drag Factor (Average G) will be **significantly less** when using the external activation switch because of the increase in time due to the braking systems mechanical reaction time. The activation switch may be connected to any 5 – 36VDC input.

Figure 46: External Activation Switch input

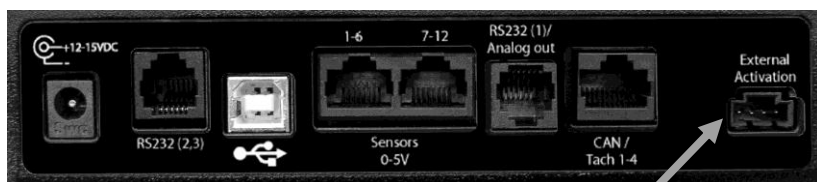

Plug reaction timer or other 12VDC activation source here.

Plug in cable before turning the VC4000 power on. To install the external activation input use an External Activation cable available

from Vericom Computers, Inc. Or make your own using a connector and solder sockets available from electronics distributors.

BOM:

Description	Part Number
Molex SL 0.10" crimp housing, Version G	Molex, 50-57-9404
2x Box crimp terminals	Molex, 16-02-0102

Assembly instructions:

1. Solder two crimp terminals to one end of the wires.
2. Place the positive wire terminal into pin 1 of the housing.
3. Place the ground wire terminal into pin 2 of the housing.

**Figure 47: Molex crimp housing**

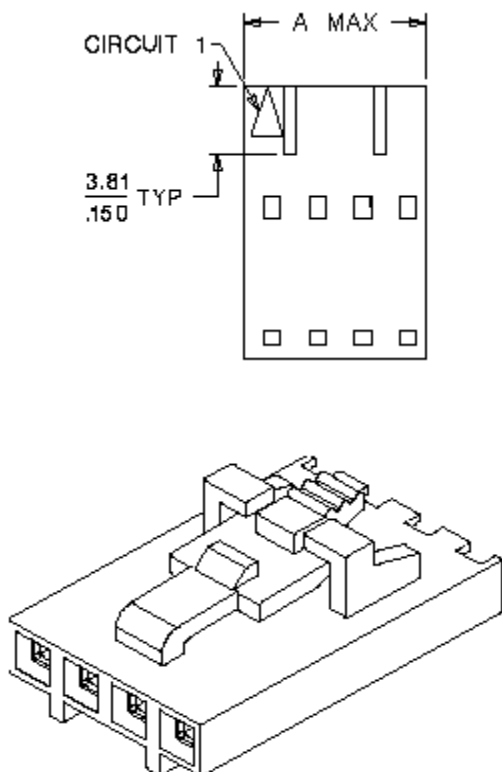

Insert the black 4-pin connector of the cable into the External Activation connector located in the back of the VC4000.

To perform a braking test using the external activation switch:

1. From the READY screen press **Braking** (VC4000 will zero adjust itself).
2. Press **Auto Start**. The VC4000 will display 'Auto Start ready'.
3. Accelerate the vehicle to the desired initial braking speed.
4. After reaching the desired initial braking speed, brake as efficiently as possible until the vehicle comes to a complete stop.
5. If using a reaction timer switch, press the switch prior to hitting the brakes.

**E/T** will be the time from when the switch was activated to when the vehicle came to a complete stop. **Reaction time** is the time from when activated to the G-Force threshold. Speed will be the speed when the switch was activated. Distance will be the distance from where the switch was activated to where the vehicle came to a complete stop. **Reaction distance** is the distance traveled during the reaction time.

To avoid false triggering of your braking run, you may press **Auto-Start** at **any time after zero adjusting**. If connected to the brake lights your foot may be on the brake pedal when the **Auto Start** key is pressed but the next time the brake lights come on the unit will activate. You may need to set the G-Threshold high enough so it doesn't activate before the external trigger. If the **G-Threshold** is not reached during the test, the VC4000 will run for a minimum of 10.00 seconds, so set the threshold to a value that will be reached during the test. See G-Threshold in Setup on page 71. You can test the operation of the switch before doing a run by pressing the **Braking** key, let it zero adjust, press the **Auto Start** key, then press the brake pedal. The VC4000 should run for 10.00 seconds then shut off.

## 9. REVIEW - PRINT DATA

This section describes various ways to review and print the data and save it to a flash drive.

Data is displayed after completing a test. Test data can be displayed on the screen, printed or saved to the SD Flash memory card (SD Card) anytime. Press the **Select Run** key on the keypad.

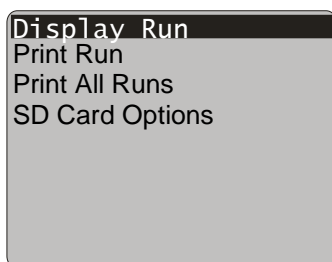

**Display a Run**

From the menu select "Display Run". Type a number using the keypad or press **ENTER / YES** to select the last run. The data is displayed on the screen. Any changes to setup such as Pitch factor or User Type will change how the data is presented or change the calculated values.

## Print Runs

Figure 48: Thermal printer



The portable thermal micro printer must be connected to one of the VC4000 RS232 serial ports. The RS232 port must be set up for printing using Setup. See “VC4000 Setup/RS232 ports” on page 79 for more details.

From the menu select “Print Run” or “Print All Runs”. Type a number using the keypad or press **ENTER / YES** to select the last run.

## Store to SD Flash drive

From the menu select “SD Card Options”.

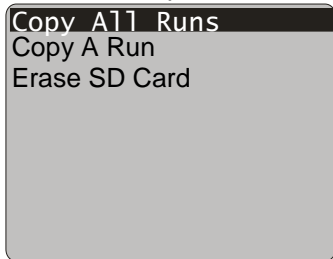

Copy All Runs	Copy all runs stored in the VC4000 memory to the SD Card
Copy A Run	Only store one run to the SD Card
Erase SD Card	Erase all data and format the SD Card

When only copying one run type the run number using the numeric keypad or press **ENTER / YES** to select the last run.

If runs are already on the SD Card, copying a file with the same run number will **overwrite** the run on the SD Card.

## 10. PC INTERFACE

This section explains the interface between the VC4000 and a computer.

The VC4000 has three ways to connect to computer to transfer the data to our "Profile" software.

<b>RS232 port</b>	<ul style="list-style-type: none"><li>○ One of three RS232 ports</li><li>○ 19.2Kbps baud rate</li><li>○ Can use wireless modem (7 mile range)</li></ul>
<b>USB port</b>	<ul style="list-style-type: none"><li>○ USB 1.1 compatible</li><li>○ 12Mbps baud rate</li><li>○ Requires Vericom drivers for Windows</li></ul>
<b>Bluetooth</b>	<ul style="list-style-type: none"><li>○ Wireless connection</li><li>○ 57.6Kbps baud rate</li><li>○ 350 Meter range</li><li>○ Requires initialization</li><li>○ Requires connection setup to computer</li></ul>

The VC4000DAQ is designed for use with the PC compatible software "Profile". With Profile, Time, Longitudinal G, Lateral G, Vertical G, Speed, Distance, Horsepower, RPM, Torque, Gear ratio and many additional sensors plus OBDII parameters can be analyzed and compared. Profile is a powerful program utilizing graphs and data tables to analyze every sample of data with the VC4000. Once a connection to the computer is established and the VC4000 is turned on, no additional key presses on the VC4000 are required. Profile controls communications. See Profile Software Manual for software description and USB driver installation.

Only Profile can be used to transfer the data from the VC4000. Once the data is imported into Profile, it can be exported to ASCII and opened by Microsoft's Excel spreadsheet program or other software that reads ASCII data.

Note: Plug in USB cable or RS232 cable before turning VC4000 power on.

## RS232 Ports

To transfer data from the VC4000 to Profile using a computer's RS232 serial port, Vericom's RJ12 to 9 pin DSub cable must be used, P/N 130409. If you must use the RS232 port on the VC4000DAQ and your computer does not have an RS232 port, you will have to buy an RS232 to USB converter. You will find these at any computer or electronics store or at an internet store and the price should range from \$20 to \$50.

Three RS232 serial ports are available on the VC4000DAQ. To transfer data through one of the three ports you must set one of them to "Data Transfer" in Setup. Go to Tools/Setup/RS232 Port/Data Transfer and choose Port 1, 2, 3 or Bluetooth. See Setup on page 79 for more information.

**Figure 49: RS232 ports**



The ports are marked on the back of the VC4000. "RS232(1)/Analog out" is port 1. In order to use the Analog output feature and use RS232 port 1, Vericom's RS232/Analog out splitter is required.

**Figure 50: RS232/Analog splitter**

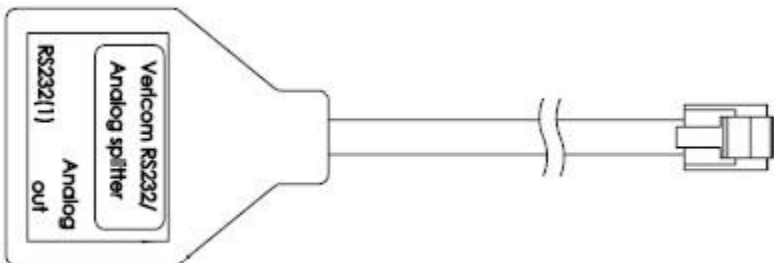

This splitter will only work on port RS232(1)/Analog out.

“RS232 (2,3) is port 2 and 3. Vericom’s RS232 splitter is required to use port 3 or use ports 2 and 3 at the same time.

**Figure 51: RS232 two port splitter**

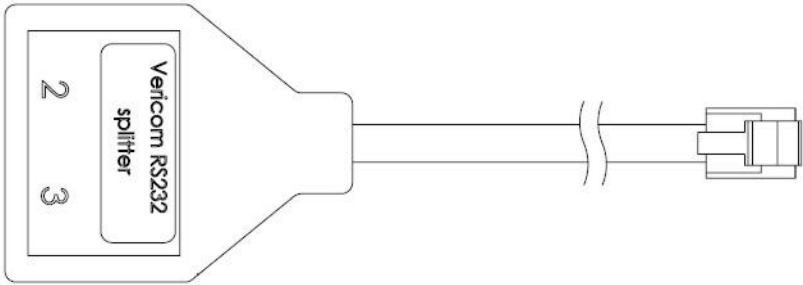

This splitter will only work on port RS232(2,3).

To use the wireless modems available from Vericom Computers, Inc. the port must be set to “Data Transfer”.

1. Plug the provided RS232 to PC cable into your computer and into the VC4000 RS232 port.
2. In Profile click on the menu Tools/Options (or click the icon) and set the COM port to “Auto” or specifically choose the COM port (usually port 1).
3. To import data click on the menu Import/Auto (or click the icon). To set or get VC4000 settings click menu Tools/VC4000 Setup (or click the icon).

## USB Port

The Universal Serial Bus (USB) port built into the VC4000 is a slave device and uses a USB “B” type connector. A slave device means that it must have a master device, ie computer, to control it. To use the USB connectivity your computer must have the **USB driver** installed which is provided on the Profile CD. See Profile help or manual for more information.

**Figure 52: USB port**

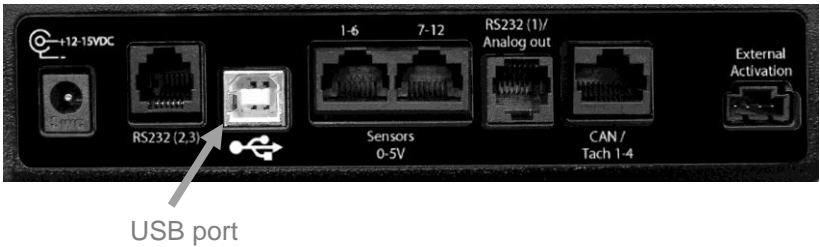

1. Plug the provided cable or standard USB cable into your computer and into the VC4000 USB port. A USB icon will appear at the bottom of the screen to indicate valid connection.
2. The first time you plug the VC4000 into your computer it will detect new hardware and ask you to install the drivers for it. With the Profile CD in the drive, follow the prompts and accept the defaults. Choose “Continue anyway” if that prompt comes up.
3. In Profile click on the menu Tools/Options (or click the icon) and set the COM port to “Auto” or specifically choose the COM port (usually the highest one listed).
4. To import data click on the menu Import/Auto (or click the icon). To set or get VC4000 settings click menu Tools/VC4000 Setup (or click the icon).

## Bluetooth

Bluetooth is a **wireless communication** connection. The VC4000 has Bluetooth communication built in. In order to use Bluetooth to import data to Profile your computer must have Bluetooth communication. Many portable computers have it built in. If your computer does not have it built in a USB to Bluetooth converter is available at most electronic retailers.

The range of the VC4000 Bluetooth connection is about 350 Meters, but will be limited to the range of your computers Bluetooth connection. The VC4000 **MUST** have **Data Transfer set to Bluetooth** in Setup to work. Only one VC4000 should be powered on within proximity of the Bluetooth enabled computer.

To set the VC4000 to send data via Bluetooth:

1. From the "READY" screen press the  key.
2. Scroll to **Setup** and press **ENTER / YES**.
3. Select **RS232 Port**.
4. Select **Data Transfer**.
5. Select **Bluetooth**.
6. Press **CLEAR / NO** until the READY screen shows.

To install the USB to Bluetooth converter:

1. Plug the converter into a USB port
2. Follow the manufacturer's procedure to install drivers
3. Turn the VC4000 on
4. Click on the Bluetooth icon on the Windows taskbar



5. Click on Add new device. Click the check box for "My device is set up and ready to be found" then click Next.
6. After it finds devices, double click on "VC4000 New device"
7. Click on the radio button labeled "Use passkey found in the documentation", and enter 0000 in the box.
8. Click on Next >. Windows will install drivers for it.
9. Look at and remember or write down the Outgoing COM port number.
10. Click on Finish.
11. In Profile, set the COM port number to the **Outgoing COM** port of the Bluetooth connection.

The wireless connection will stay active until the VC4000 is shut off or until the computers Bluetooth connection is terminated. Import data to Profile as usual.

Bluetooth is slower than USB. Long delays may occur when using Bluetooth so be patient when importing using Profile and Bluetooth communication.

With Data Streaming, a Bluetooth connection is not recommended because sometimes Windows will terminate the connection.

# 11. UPDATING FIRMWARE

This section describes how to update the firmware using the VC4000 Reflash program.

The firmware (software that runs the VC4000) in the VC4000 is designed so it can be updated by the user. First you will need a connection from the VC4000 to your computer. See PC Interface on page 112. Next you will need the binary program file. This can be found on our web site:

[http://www.vericomcomputers.com/Support/VC4000\\_Support.html](http://www.vericomcomputers.com/Support/VC4000_Support.html) or from an email attachment.

To update the firmware:

1. Install Reflash (VC4000ReflashSetup.exe)
  - a. From the Profile 4 CD
  - b. Download from the VC4000 support page
2. Download latest firmware from web site. See above link.
3. Start the reflash program found at Start/Programs/Vericom Computers/VC4000 Reflash.
4. Before starting the process plug the wall adapter into the VC4000 so the battery won't go dead in the middle of an operation.
5. Connect VC4000 to computer. See PC Interface on page 112.
6. Erase all run memory in the VC4000.
  - a. Press the **CLEAR / NO** key from the READY screen.
  - b. Then press **ENTER / YES** twice.
7. Set the port to "Auto" or specify the port that the VC4000 is connected to.

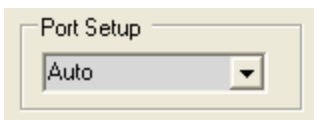

8. Click the "Connect to VC4000" button.

9. Once connected an open dialog box will show. Open the .BIN file with the new firmware. Make sure it is the same VC4000 model firmware or it will not work. Ex. VC4000DAQ123.BIN



10. Click the Re-Flash button.
11. When downloading to memory is done the program will ask you to power off the VC4000, then back on. When the VC4000 is turned back on it will transfer the firmware into the program area of flash memory.
12. Then it will ask you to hold the power button, after which it will delete the run file flash memory.
13. The reflash program may be exited after the ③ is shown and the VC4000 displays "Power off & on"
14. Reflashing firmware is complete.

If power is lost in the middle of the reflash process, the VC4000 will have to be sent back to the factory for reflashing.

Please note that an update to firmware may require you to update Profile 5.

## 12. CHARGING THE BATTERY

This section describes how to properly charge the battery.

The battery charger inside the VC4000 requires 12 to 16 Volts DC at 800 milli Amps or greater to operate, so most regulated 12V battery chargers will work. Suitable chargers are available from Vericom Computers, Inc. The center conductor of the VC4000 power adapter is positive, and the connector has a 5mm OD and a 2.1mm ID. The VC4000 will charge from a vehicle's cigarette lighter. It takes about **three** hours to fully charge them. The batteries take about **six** hours to fully discharge.

The battery gauge on the display will show arrows indicating that the battery is charging. The green charging LED on the front of the unit will light while it is charging and go out when it is fully charged. The green LED will turn on anytime the unit is plugged in and stays on until the battery is fully charged.

**DO NOT** use the charger from the VC4000 to charge or power the portable thermal printer. It is reverse polarity and **WILL** destroy the printer electronics. Similarly, do not power the VC4000 using the thermal printers wall adapter.

The VC4000 has protection circuitry for voltages and currents exceeding the maximum rating for the internal components, as well as reverse polarity protection. But continuous over voltages or reverse voltages may eventually cause damage to the input circuitry.

## 13. CUSTOMER SERVICE

This section describes Vericom's warranty, repair and Accessories.

### Warranty

The manufacturer warrants that the VC4000 computer will be free from defects in material or workmanship appearing under normal use and service. This warranty extends only to the original purchaser and does not apply if the product has been connected, installed or adjusted other than in accordance with the instructions furnished by the Manufacturer.

The manufacturer will repair or replace any parts that are defective in workmanship or materials for a period of one year from the date of purchase. The manufacturer does not warranty the installation of the VC4000 computer and therefore will not be responsible for damage caused by installation.

This warranty covers only the VC4000 computer and is not extended to equipment or component parts used in conjunction with the VC4000 computer. The manufacturer will not be liable for incidental and consequential damages or the loss of use of your vehicle.

This warranty gives you specific legal rights and you also may have rights that vary from state to state.

### Repairs

Repairs not covered by warranty are available by returning the unit, prepaid postage, to the manufacturer. Repair charges and shipping will be billed to the customer prior to repairing or returning the unit to the customer.

Please include the following information when returning a VC4000:

1. Your name
2. Company name
3. Shipping address
4. Daytime telephone number
5. Model and Serial number of unit being returned
6. Description of problem
7. Method of payment
8. Description of any upgrades or repairs since purchased

For service, repair or product information contact:

Vericom Computers, Inc.

14320 James Rd

Suite 200

Rogers, MN 55374

763-428-1381

Fax 763-428-4856

[vericom@vericomcomputers.com](mailto:vericom@vericomcomputers.com)

[www.vericomcomputers.com](http://www.vericomcomputers.com)

## Options, Upgrades

- Analog sensor input
- OBDII Monitoring
- 5Hz GPS location, altitude and speed
- Portable micro thermal printer
- 12V activation cable
- Brake pedal activation switch
- Brake Reaction Timer hardware (software is included standard).
- Junction box for 6 sensors into 1 modular connector
- Stripped wire to modular converter
- RS232/Analog out splitter
- 2 input RS232 splitter
- CAN/Tach/Digital input splitter
- Analog output cable
- Dual vacuum cup mounting kit
- Sensor Options (See separate data sheets.)
  - Brake pedal load cell
  - Tri axis accelerometer
  - Crash G sensor
  - Air pressure sensor
  - Brake caliper pressure sensor
  - Contact factory for other sensors
  - More
- Tachometers
  - a) Coil Pickup
  - b) Inductive Pickup
  - c) Magnetic Pickup
  - d) OBDII engine speed

## 14. TROUBLESHOOTING

This section describes some problems that may arise and solutions to those problems.

<b><u>Problem</u></b>	<b><u>Solution</u></b>
Unit doesn't turn on	<ul style="list-style-type: none"><li>• No power to cigarette lighter plug. Check connection to plug, or fuse in plug, or power to cigarette lighter.</li><li>• Cigarette lighter cord not making connection to VC4000. Push right angle plug all the way into VC4000.</li><li>• Dead battery. Plug into cigarette lighter or wall adapter.</li></ul>
Unit turns off or resets during run.	<ul style="list-style-type: none"><li>• Loss of power to VC4000. Check power cord and fuse.</li><li>• Battery went dead. Recharge battery.</li><li>• Electrical noise interference. Eliminate noise from source.</li><li>• Static shock triggered safety circuit. Press any button or power back on.</li></ul>
Inaccurate data	<ul style="list-style-type: none"><li>• VC4000 was not at same incline as when zero adjusted or level of VC4000 changed since zero adjusting. See page 4 for mounting.</li><li>• Summation was not on and unit was mounted at an angle.</li><li>• VC4000 started timing too soon. If 3D summation is on a bump may have triggered it. See page 71 to adjust threshold.</li><li>• Electrical noise interference. Eliminate noise from source.</li><li>• Wrong pitch and roll factor for vehicle. See page 74 to adjust pitch and roll factor.</li><li>• Settle time was calculated wrong. Import to Profile and set it manually.</li><li>• Vibration: Mount level and turn Summation to</li></ul>

	2D or mount straight and level and turn summation off. Or mount on foam pad.
RPM inaccurate	<ul style="list-style-type: none"> <li>• Wrong Tach factor. Set correct tach factor for engine.</li> <li>• Tachometer not connected properly. See page 103 for proper connection.</li> <li>• Wrong sensor for application. Contact factory for proper sensor.</li> </ul>
Unit is unresponsive to keypad	<ul style="list-style-type: none"> <li>• Program is locked up. Short pins 1 and 2 of the external activation input to reset it. See if updated firmware is available.</li> </ul>
Power is on but display is blank	<ul style="list-style-type: none"> <li>• Press the <b>CLEAR / NO</b> key on the keypad. Sudden voltage swings can cause this.</li> </ul>
GPS not working	<ul style="list-style-type: none"> <li>• GPS not on: Turn GPS on and/or GPS speed on in Setup.</li> </ul>
Compass not working	<ul style="list-style-type: none"> <li>• Turn compass on in Setup.</li> <li>• Not calibrated.</li> </ul>
Rate gyro not working	<ul style="list-style-type: none"> <li>• Turn Gyro on in Setup.</li> </ul>
Bluetooth not working	<ul style="list-style-type: none"> <li>• Data Transfer in VC4000 Setup not set to "Bluetooth"</li> <li>• VC4000 not turned on</li> <li>• Wrong COM port selected in Profile Options</li> <li>• COM port in computer not setup.</li> <li>• Other – Remove all Bluetooth devices from Windows and start over</li> </ul>
FLASH-ERROR	<ul style="list-style-type: none"> <li>• There was a problem writing to the flash memory. Import data to Profile if necessary and clear memory</li> </ul>
RUN-FILE-FULL	<ul style="list-style-type: none"> <li>• Memory is full. Import data to Profile if necessary and clear memory</li> </ul>
RUN-FILE-LEN	<ul style="list-style-type: none"> <li>• File is too long for memory capacity</li> </ul>
ARITHMETIC EXCEPTION	<ul style="list-style-type: none"> <li>• Divide by 0 error. Power off and back on</li> </ul>

## 15. SPECIFICATIONS

Computer: High performance 32 bit ARM core, 48 MHz,  
Memory: 4MB Flash run storage, 16KB Flash data,  
256KB ROM 64KB RAM

Charging Voltage: 8 – 16VDC  
Nominal Battery life: 6 hours

Temp. Range: -20° F to 160° F

### Accelerometer

Range:  $\pm 2$  or  $\pm 6$  G range  
Minimum Resolution: 0.001 G  
Shock survival: 10,000 G  
Bandwidth/sample rate: 1 - 1000Hz  
Accuracy:  $\pm 0.0030$  G

### Analog Sensor input

Range: 0 – 5VDC  
Resolution: 16 bits  
Accuracy:  $\pm 0.6$  LSB  
Sample rate: 1 - 1000Hz

### Analog Output

Range: 0 – 5VDC  
Resolution: 12 bits  
Accuracy:  $\pm 2$  LSB

### Angular Rate Gyro

Range:  $\pm 150^\circ/\text{sec}$   
Accuracy:  $0.15^\circ/\text{sec}$   
Linear Acceleration effect:  $0.2^\circ/\text{s/G}$   
Shock survival: 2000 G

### Compass

Range:  $\pm 6$  gauss, 360 degrees  
Resolution: 1 degree

### Tachometer

Range: 0 – 15,000 RPM  
Accuracy: 0.05 RPM  
Resolution: 1 RPM

External Activation: 5V-36V DC

Bluetooth  
Range: 350 meters  
Frequency: 2.4GHz

Digital inputs  
Low signal (off) 0.80V  
High signal (on) 2.0V

Power cord  
Length: 6 feet  
Plug: 2.5 mm ID  
(center positive): 5 mm OD  
(Right angle Preferred): 10 mm L  
Fuse: 1.25 inches, 3 AG, 1 Amp

Dimensions: 6.75 inches long, 3.50 inches high, 4.40 inches deep

Manufacturer: Vericom Computers, Inc.  
14320 James Rd  
Suite 200  
Rogers, MN 55374